

The logo for Fornley, featuring the word "Fornley" in a stylized, bold, italicized font with a horizontal line extending from the end of the word.

# MODEL PTO-15F & PTO-20F

## Operating and Service Instructions

The logo for Fornley, featuring the word "Fornley" in a stylized, bold, italicized font with a horizontal line extending from the end of the word.

**Industries, Inc.** U.S.A.

Box 563 Fort Collins, Colo. 80521 U.S.A. • Box 1040, Regina, Sask. Canada • 45 Shirley Ave., Kitchner, Ontario Canada

**Arc Welders Ltd.** CANADA



0-21 369

INSTALLATION AND OPERATION INSTRUCTIONS  
TRACTOR PTO ALTERNATOR  
15,000 and 20,000 WATT MODELS

The Forney Tractor PTO Alternator is a rugged heavy-duty electric Alternator Power Plant that will provide an economical and dependable source of electrical power either as a portable or standby unit.

This Alternator is designed to be driven by a tractor power take off or other engine sources of power that will provide 520 RPM to the Alternator gear box.

**IMPORTANT.** Each Alternator is carefully inspected at the factory and a run in is made until the brushes are satisfactorily seated. The unit then is carefully checked for the correct output under the average operating conditions. No Alternator is shipped unless it produces its full rated capacity, nor until it has passed all rigid inspection tests. Before operating be sure that all installation requirements and instructions are followed. If for some reason the Alternator does not work properly, be sure to check all electrical connections that may have come loose in transit, and tractor PTO speed before reaching the conclusion the Alternator is not performing satisfactorily.

Before operation is attempted, OIL MUST BE CHECKED IN THE GEAR CASE. Oil should be checked periodically and if found low simply remove the breather from the top of the gear case and the oil level plug from the back of the gear case. Pour the oil (90 wt. gear lub) in the gear case, until it begins to come out of the oil level hole, then install both the plug and the breather cap.

The PTO Alternator should be securely bolted to a platform or a trailer. If your Power Unit is to be used strictly for standby and permanently located, a suitable base can be provided by pouring a block of concrete at least 8 inches thick and approximately 2 feet square and before the concrete is set bolts can be inserted into the concrete to match the alternator bolt-down holes. Another method would be to weld a platform out of heavy iron; for instance, railroad rails or heavy channel iron to provide a suitable base that is firmly anchored to the ground. If either of these methods of mounting is used, the Alternator is firmly anchored so it will not move during operation, and care should be taken that the tractor will not move or creep during operation. Wheelchairs, suitable brake on the wheels, or a connecting bar to the Alternator mount can be used.

If you intend to use the Alternator as a Portable unit, it should be mounted firmly to the bed of a trailer or skid. However, in either case there must be a tongue or towbar anchored firmly to the tractor and to the trailer or skid. This is to prevent the Alternator from separating from the tractor allowing the tumble bar to separate and become dangerous.

The Alternator should be installed in a location that allows the normal built-in fan cooling of the unit to operate satisfactorily. The amount of ventilation required will depend on several factors such as outdoor temperature, the size of the room (if mounted in a building with connection to tractor through a doorway or opening), the amount of natural air circulation in the room, and other heat-producing equipment that may be nearby. Under no circumstances should the temperature in the room or area be allowed to reach 120°F. If the unit is to be used outdoors, it is best if it can be located in a shady area or shade provided for it, but under no circumstances attempt to operate the unit with a box or tight enclosure around the unit.

Excessive dirty or dusty areas should be avoided in locating your Alternator only from the standpoint of the tendency for dirt or debris to clog the ventilation slots of the unit and thus cause excessive heating. Dirt in the air also causes excessive wear on the brushes and will contribute to higher maintenance costs.

The gear train in the gear box has a step-up ratio of 6.92 to 1 for both the 15,000 and 20,000 watt models. A speed of 520 RPM is required to drive the Alternator at 3600 RPM to deliver 60 cycle power. If the 15,000 watt Alternator is intended to be used for the 12,000 watt continuous duty level, a horsepower of 26.4 will be required to operate the Alternator. If it will be used utilizing the full 15,000 watts of intermittent power, a tractor horsepower of 33 will be required. If the 20,000 watt Alternator is intended to be used for the 15,000 watt continuous duty level, a horsepower of 30 will be required to operate the Alternator. If it will be used utilizing the full 20,000 watts of intermittent power, a tractor horsepower of 40 will be required.

All engines have a tendency to slow down when a load is applied. It is important that the governor on the engine is designed and adjusted to hold the speed nearly as constant as possible. The slight decrease in speed from the tractor along with the normal small voltage drop within the Alternator itself results in slightly lower voltage when the Alternator is loaded to its full capacity than when running idle. The resulting frequency variation has no appreciable effect on the operation of motors, lights, and most appliances; however, accurate timing devices such as clocks, will not keep perfect time when used on these Alternators.

The Forney Tractor PTO Alternator is equipped with a voltmeter for adjusting the speed and is also equipped in the same control box on the rear side with the rain-type cover outlet connections for both 230 volt and 115 volt. The Forney AC Arc Welders can be used from this Power Unit by plugging them into the 230 volt outlet in the control box. The two 110 volt outlets are rated 15 amps each for lights, electric drills, etc. If more capacity on 115 volts is needed, it is recommended that the load be wired directly to the connections inside the control box with suitable fusing or breakers supplied. Also if the unit is to be used for standby power on 230 volts, either the 230 volt plug-in can be used or if the local codes require again direct connection can be made to the leads inside the control box.

Adjust the throttle setting of the tractor to produce a voltage of approximately 260 volts on the voltmeter when no load is applied. With a good sensitive governor on the tractor engine the voltage will vary approximately as follows on the chart shown on page 3 and depending upon the electrical load connected to the Generator:

PTO-15, 15,000 Watts

<u>Watts</u>	<u>Volts</u>	<u>Frequency</u>
0	260	61
3000	256	60+
6000	252	60
7000	246	60-
12000	238	59
15000	230	58+

PTO-20, 20,000 Watts

<u>Watts</u>	<u>Volts</u>	<u>Frequency</u>
0	260	61
3000	258	61-
6000	256	60+
7000	252	60
12000	246	60-
15000	238	59
18000	232	59-
20000	230	58+

Low voltage may damage both the Alternator and any motors or appliances connected to it. Running an Alternator at excessively high speeds results in too high a voltage, which may also damage electrical devices connected to it. Excessively high speed may also cause damage to the armature winding. It is good practice to check the Alternator periodically to determine if the correct speed is used.

If the unit is to be used as standby power or emergency power, it must be equipped with some suitable disconnect to prevent damage to the Alternator when the powerline current from the power company is reinstated. A suitable double throw, double pole switch should be used when connecting to any loads normally served by a power company. This switch should be installed so that it completely disconnects the power company circuit when the Alternator is connected to your electrical load. When your normal power comes on, you can disconnect the Alternator from the load and connect the powerline to the load. These transfer switches are available from Forney Industries at a low cost and are good insurance against damaging the Alternator.

The power required to start any electric motor is considerably more than is required for keeping it running after it is once started. Some motors require much more current to start them than others. Split phase AC motors require more current to start under similar circumstances than other types. These are commonly used on easy starting loads such as on washing machines or where loads are applied after the motor is started, such as small power tools. Since they require five to seven times as much current to start as to run, their use should be avoided whenever possible, if the Alternator is already loaded near its maximum capacity. Capacitor motors and repulsion reduction motors require from two to four times as much current to start them as to run them. The current to start any motor varies with the load connected to it. An electric motor connected to an Air Compressor for example will require more amperage than a motor to which no load is connected.

## MAINTENANCE

**BRUSHES** -- Check the brushes for wear after about 1000 hours of operation and every few hundred hours of operation thereafter. They should be replaced when worn down to 1/2 inch. Whenever replacing brushes or removing them to do other service work, remove one brush at a time and put the screws back into the brush holder to hold the lead wire terminals in place so there will be no difficulty in connecting the wires to the correct positions.

**COMMUTATOR** -- A commutator in good condition has a glossy finish and is brownish in color. If it gets greasy, rough or dirty, it may be cleaned with very fine sandpaper. (Do not use emery cloth.)

**BEARINGS** -- All ball bearings used in these Alternators are packed with grease before assembly -- no further greasing is required. If they become rough or worn they should be replaced.

## LOCATING TROUBLE

If the Alternator does not work properly, first check the conditions under which it has been operating and then if necessary make the electrical tests as outlined below:

1. Is the speed correct? Check the speed with a tachometer or frequency meter and adjust the engine governor if necessary. If the Alternator cannot be kept to specified speed when it is loaded to its rated capacity the engine is too small, or is not working properly or the governor is not sensitive enough to hold the speed constant over a wide load range.
2. Is the Alternator overloaded? Check the nameplate for maximum safe load and if uncertain about the amount of load, check it with an ammeter and voltmeter.
3. Is the location satisfactory? See "Location" regarding sufficient ventilation if the Alternator is being operated in an enclosed area. If it is being operated under dusty or dirty conditions be sure all ventilation holes and slots are cleaned periodically.
4. Is the commutation satisfactory? With the Alternator in operation, notice whether there is any appreciable arcing or sparking at either the AC or DC brushes. See the article on brushes under "Maintenance".
5. The Alternator is equipped with a voltmeter to indicate that the unit is producing electricity. If the voltmeter does not register, check the output with a bulb or meter before deciding that the Alternator is not performing as it should.
6. If no output voltage is obtained at the outlet receptacles or output wires, disconnect all electrical leads and connect a voltmeter directly to the AC brushes. If no voltmeter is available, use any ordinary small 115 volt bulb (230 volt bulb on 230 volt Alternators). If normal voltage is obtained at the AC brushes but not at the output terminals, there must be an open circuit between these points. (CAUTION -- On 115/230 volt plants, the center brush is neutral and grounded. Check from this brush to each of the other two brushes.)

7. If no AC voltage is obtained at the brushes, check the excitor voltage by connecting to the DC brushes. The voltage should be at least 16 volts. This voltage will produce a dim light if a 115 volt bulb is used. If the DC voltage is satisfactory omit Step 8 and proceed with Step 9.
8. If no voltage is produced at the DC brushes, proceed as follows:
  - a. Remove each of the DC brushes to be sure they are clean and free in the holder. Examine the brush springs to make sure they have several ounces of tension. Replace all parts necessary.
  - b. One side of the DC circuit and one side of the AC circuit is connected or "grounded" to the alternator frame. The other side is said to be "live" or "hot". Any short circuit between the "hot" side or either circuit and any metal part of the alternator will result in a grounded condition which prevents the alternator from producing electricity. Carefully inspect all "hot" wires and terminals for evidence of a grounded condition.
  - c. Using an ohmmeter, check the field circuit for open circuits. To do this remove one of the field coil leads from the brush and check from this terminal to the other DC brush. If the circuit is open, check it for loose connections. If the alternator has a resistor in the field circuit, also check the resistance across it (or the part of it being used) to determine if it is "open". Replace all necessary parts.
  - d. If the trouble still is not located, disconnect all field leads and with an ohmmeter, check from either field coil terminal to the alternator frame to be sure the field coils are not grounded. If they are grounded, they should be replaced.
  - e. If the unit has not been operated for an extended period of time, the field poles may have lost "residual magnetism." To magnetize ("flash") the field poles use a 12 volt battery. Connect the negative terminal of the battery to the Negative (grounded) DC brush. Then connect the Positive battery terminal to the Positive DC brush for about one or two seconds. Do not connect for more than a few seconds or permanent damage to the field coils may result.
  - f. Remove all lead terminals from the AC brushes. If the alternator builds up voltage with these wires disconnected, there is a short circuit in the condensers or control box. Isolate and correct the short circuit.
  - g. If all the previous tests are of no avail, remove the armature and have it tested for opens, shorts and grounds on a growler. The same equipment and procedure as is used for testing DC generator armatures also applies to these armatures.
  - h. If the armature tests satisfactorily check the DC brush holders for grounds (this applies to metallic brush holders only).

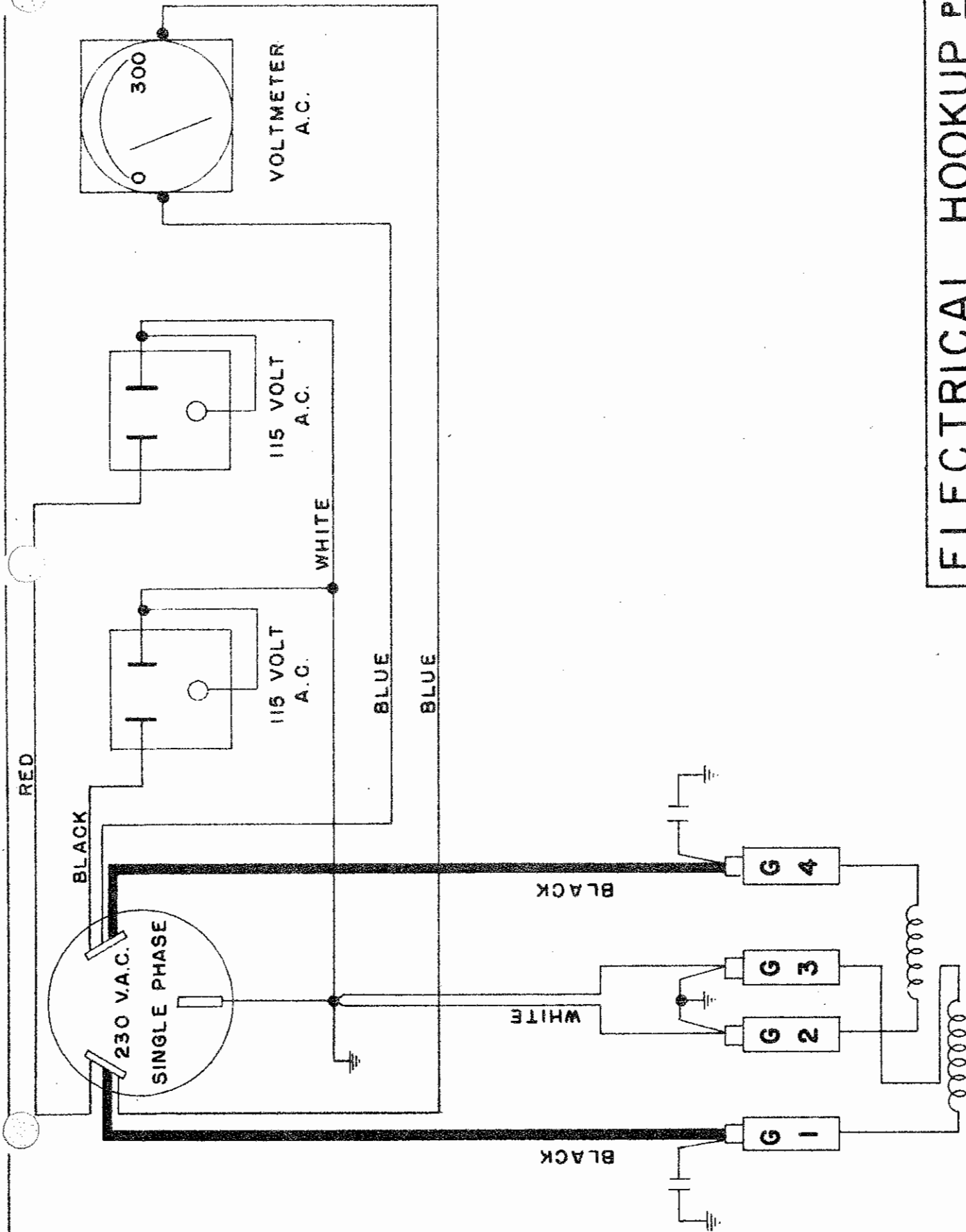

# ELECTRICAL HOOKUP PT020/15

DRAWN	PKW	DWG. NO.	04867
DATE	12-20-68	FORNEY MANUFACTURING CO.	
SCALE	NONE	DIV. OF FORNEY INDUSTRIES, INC.	
TOL.	± .XX .032	FORT COLLINS, COLORADO	

# PTO (POWER TAKE OFF) ALTERNATOR

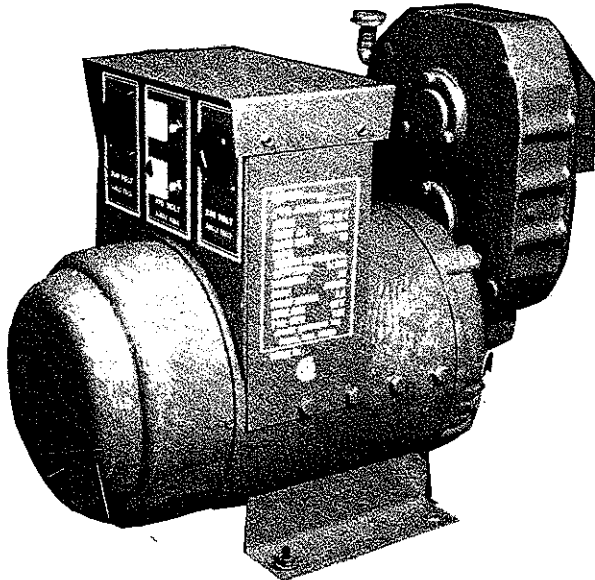

**PERHAPS** you have experienced power failure at some time. If so, we don't have to remind you that the losses can be heavy. Practically everything stops when power is cut off - no lights, water, heat, coolers, freezers, refrigerators, power tools, feeders, milkers, radio and TV. In a moment's time a tornado, hurricane, blizzard, flood or lightning could plunge your whole operation into costly confusion - unless you have auxiliary power. Fasten this unit on a two-wheel trailer, attach the power take-off on your tractor and you are ready for any job any place, whether there is power or not.

## PORTABLE or STANDBY

### MOST COMMONLY USED MODELS

PTO-15-1	PTO-15-3	PTO-20-1	PTO-20-3
Cat.#600-0	Cat.#601-0	Cat.#605-0	Cat.#606-0

## FEATURES

- \* 3600 RPM Armature
- \* 540 RPM Tractor PTO Speed
- \* Precision Gear Drive
- \* Oil Bath Gear Case
- \* Pre-lubed Sealed Bearings
- \* Burn-out Proof
- \* Cool Running
- \* Minimum Frequency Variation
- \* No fuses or Breakers
- \* Calibrated Voltmeter
- \* Compact and Light Weight
- \* Long Brush Life
- \* Radio and TV Static Checked
- \* 230/115 Volt Outlets
- \* DC Windings
- \* No Drip Insulation
- \* Minimum Maintenance
- \* Full One-Year Warranty

**ALL MODELS** have the same precision gear drive and the alternators are all burn-out proof. 3600 RPM is a plus factor for easier motor starting due to the inertia factor. Quality design holds temperature rise to approximately 50% of what NEMA standards allow. It is an excellent unit for use as a standby power source because of the minimum frequency variation and radio and TV interference has been suppressed.

**AUXILIARY POWER** designed for both 115 volt and 230 volt, 60 cycle in both single phase and three phase. 520 RPM at the gear box PTO produces 3600 RPM on the armature. The control tower is equipped with a volt meter facing the shaft for easy reading and setting of the engine speed desired. The reverse side has a rain-type cover protecting the two 115 volt outlets and the one 230 volt outlet.

**3600 RPM ARMATURE** provides greater motor starting ability through the inertia factor. The rotating armature also provides portability by less weight (same watts - smaller package) compared to an 1800 RPM rotating fields type unit. The rotating armature type has proven to be a more rugged and durable unit.

**540 RPM TRACTOR PTO SPEED** - The gear reduction makes it possible for almost any tractor to drive this unit as the 540 RPM is a very low requirement. The engine powering the unit needs only the capability of producing 2 HP per 1000 watts to assure proper operation.



## GEAR DRIVE NOT CHAIN

The precision machined helical gears are incased in rugged line-bored cast iron and run in an oil bath requiring only regular automotive type gear oil. This means quieter operation, less breakage, no links to replace, etc.

## CONTROL PANEL

When the powering source maintains the proper RPM required, the unit will have little or no frequency variation (that is, using an engine equipped with a sensitive governor). The calibrated voltmeter is located facing forward so the operator can see the meter and adjust the powering engine properly. The same control panel is equipped with one 230 volt and two 115 volt outlets, sheltered with a covering door.

## ALTERNATOR

The case is aligned-grain, rolled, welded and honed. The armature rotates inside stationary fields on pre-lubricated sealed ball bearings. The insulation is drip-proof and is of a class rating allowing up to 130° C. temperature rise by NEMA standards. Designed to give protection lasting as long as the alternator lasts. The collapsible fields provide for positive overload protection (burn-out proof) and stops electrical output and is considered a "plus" over fuses and circuit breakers. Collapsible fields reduce continued overloading to a minimum creating longer life of the alternator. They have DC windings. Capacitors are included on both load circuits and exciter circuit to minimize interference on radio and TV. There are four commutator rings and four brushes per ring and held by a metallic brush holder. Tests have shown up to 5000 hours of brush life, so brush wear is at a minimum.

## STANDBY POWER

For standby power on 230 volts, either the 230 volt outlet can be used or, if the local codes require, direct connection can be made to leads inside the control box. To even increase its versatility, the alternators can be made portable by either skid or trailer mounting the unit thereby making it possible to move it to any place that you need electric power.

## GENERATOR WELDER POSSIBLE

We have good portable welders that can be used with the PTO Alternators as their source of power by plugging them into the 230 volt outlet. The 110 volt outlets are rated at 15 amps for lights, electric drills, etc.

For those who want the most complete and economical portable power-welder unit, begin with the Forney PTO Power Alternator, then add a Forney Model F Welder, plus a Forney Acetylene Outfit and Forney Accessory Kits; place all on a two-wheel trailer, attach the power take-off to your tractor and you are ready for any job any place, whether there is power or not.

## WARRANTY

Within one year of your purchase date, your PTO fails to operate satisfactorily because of defects in workmanship or material, authorized repair will be made at our Fort Collins, Colorado factory, or by an authorized Factory Representative.

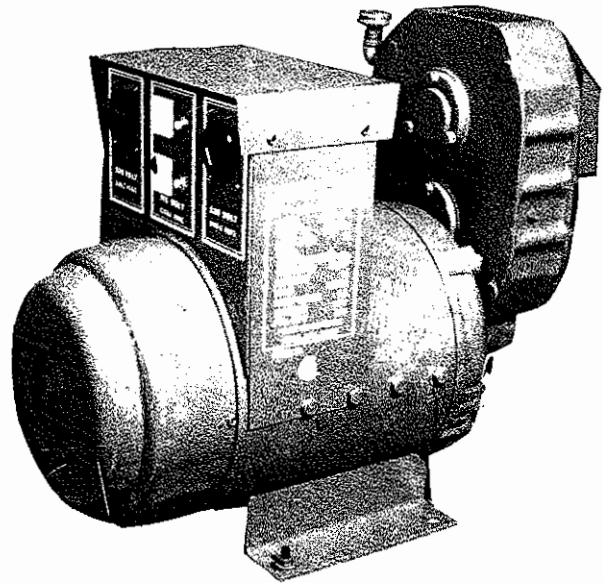

### SPECIFICATIONS of available PTO alternators

PTO-15 ALTERNATOR, single phase, 12,000 continuous, 15,000 intermittent, approx. 19,500 surge, starts 7.5 H.P. motor, runs 10-12 H.P. (25-35 H.P. tractor)

PTO-15 ALTERNATOR, three phase, 12,000 continuous, 15,000 intermittent, approx. 19,500 surge, starts 7.5 H.P. motor, runs 10-12 H.P. (25-35 H.P. tractor)

PTO-20 ALTERNATOR, single phase, 15,000 continuous, 20,000 intermittent, approx. 25,000 surge, starts 10 H.P. motor, runs 13-16 H.P. (30-40 H.P. tractor)

PTO-20 ALTERNATOR, three phase, 15,000 continuous, 20,000 intermittent, approx. 25,000 surge, starts 10 H.P. motor, runs 13-16 H.P. (30-40 H.P. tractor)

PTO-30 ALTERNATOR, single phase, 25,000 continuous, 30,000 intermittent, approx. 40,000 surge, starts 13 H.P. runs 20 H.P. 1800 R.P.M., 540 R.P.M. (50 H.P. tractor)

PTO-30 ALTERNATOR, three phase, 25,000 continuous, 30,000 watts intermittent, approx. 60,000 surge, starts 13 H.P. runs 20 H.P. 1800 R.P.M., 540 R.P.M. (50 H.P. tractor)

PTO-45 ALTERNATOR, single phase, 37,000 continuous, 45,000 intermittent, approx. 60,000 surge, starts 20 H.P. load, runs 30 H.P. 1800 R.P.M., 1000 R.P.M. on PTO. (tractor 75 H.P.)

PTO-45 ALTERNATOR, three phase, 37,000 continuous, 45,000 intermittent, approx. 60,000 surge, starts 20 H.P. load, runs 30 H.P. 1800 R.P.M., 1000 R.P.M. on PTO (tractor 75 H.P.)

PTO-60 ALTERNATOR, single phase, 50,000 continuous, 60,000 intermittent, approx. 80,000 surge, starts 26 H.P., runs 40 H.P. 1800 R.P.M., 1000 R.P.M. on PTO. (tractor 100 H.P.)

PTO-60 ALTERNATOR, three phase, 50,000 continuous, 60,000 intermittent, approx. 80,000 surge, starts 26 H.P., runs 40 H.P. 1800 R.P.M., 1000 R.P.M. on PTO. (tractor 100 H.P.)

## OPTIONAL ACCESSORIES

### LINE TRANSFER SWITCHES

Required with any self-powered or tractor-operated non-automatic alternator which is hooked into wiring system connected to hi-line. Change from hi-line to alternator power, or from alternator back to hi-line by simply throwing the lever.

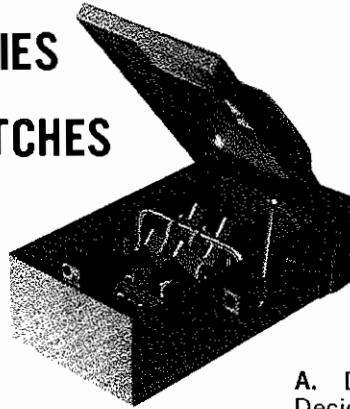

This is a heavy-duty, lift front, safety box. Non-fused, 100 Amp rating for three (3) wire 120/240 volt AC power. 13" long, 7" wide, 4" deep. General Electric design, Type G, Model I, 3SN Pole. Easy to install, foolproof connection. 200 amp boxes also available.

### PTO DRIVE SHAFT



You'll need this PTO Drive Shaft to connect your Tractor to your PTO (Power Take-Off) Alternator. This is a fine quality, heavy-duty telescoping drive shaft with double universal joints. The telescoping drive shaft is 4 ft. long and extends to 6 ft. This shaft size is 1 inch with slip over shaft of 1 3/8 inches. The protective shield is 3 inches in diameter and telescopes to coincide with the drive shaft. Complete with 1 3/8 inch x 6 inch spline to couple the power take-off to the universal joint. Universal joints are made from "forged steel".

### SHAFT ADAPTERS

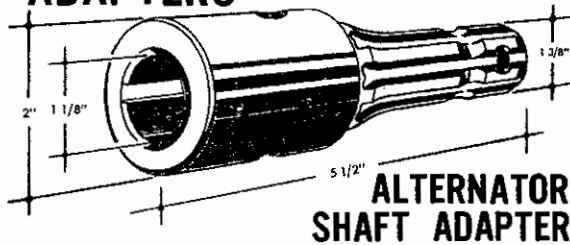

This PTO Alternator Adapter is an adapter with a fully splined male and a keyed female end to be used to attach to your PTO Alternator shaft and then to a PTO Shaft or Tumbler. The size of the male spline and female end is as shown on the drawing above.

### DRIVE SHAFT ADAPTER (REDUCER)

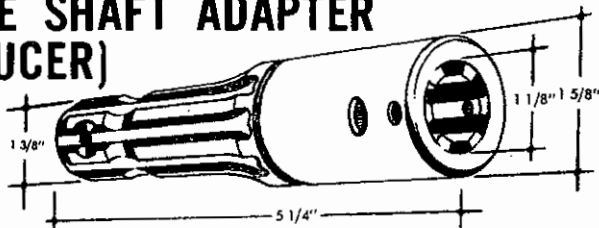

This PTO Drive Shaft Adapter or Reducer is available for the customer who desires an adapter or reducer which is fully splined to work with a tumbler bar he may already have. The size of the male and female spline ends are as shown above.

## HOW TO DETERMINE THE PROPER ALTERNATOR and EQUIPMENT

The size of the alternator: In choosing the equipment best suited to the customer's needs, the following steps should all be carefully considered:

**A.** Determine the size of the alternator that is needed. Decide which electrical equipment is to be kept running in the event of a power failure. This may include the entire load or it may be decided that certain heavy loads will not be used during the powerline outage; for example, the air conditioner, water heater, and electric range. However, since the purchase of a stand-by alternator for the home may be a "once in a lifetime" purchase, it is unwise to choose a model which will not provide reasonable comforts and convenience during a power outage. It is particularly important to carefully consider the electrical power required to start the electric motors which are to be used during the emergency. All motors require much more current to start them than it does to run them after they are started as shown in the table on page 4.

**B.** The emergency power source must be the same voltage, frequency and phase as the normal power line. If all of the circuits are to be transferred to the emergency standby alternator, the manual transfer switch should have an ampere rating equal to that of the service entrance. If only part of the circuits are to be transferred, it must have an ampere rating equal to or larger than the combined ratings of the branch circuits which are to be transferred. For example, if three circuits rated at 20 amperes were to be transferred in a 115/230 Volt system, neither main branch exceeds 60 amperes so a Transfer Switch with a rating of 60 amperes is large enough.

**C.** To determine the Alternator capacity required for the standby load:

1. List the "starting" watts for all "automatic" appliances as refrigerators, freezers and furnaces.
2. List the wattage of all lights and heating devices, such as toasters and percolators.
3. List the "running watts" of all motors which will be turned on manually, such as sump pumps or pressure pumps, and left turned on while other "automatic" appliances such as refrigerator and furnace blower will be used.
4. Determine the sum of 1, 2 and 3 above.
5. Recheck the motors in Item # 3 to be sure that none of the motors require more power for starting than can be supplied by the alternator.

**EXAMPLE:** A suburban home has the following requirements for minimum standby service: A 1 HP. deep well jet pump which will be turned on manually during standby service, a refrigerator (1/6 HP. cap.) and furnace blower (1/6 HP. cap.) which operated automatically, 200 watts of light in the kitchen, 500 watts in the living room, 150 watts in the bathroom and 150 watts in other locations:

Pump (1 HP. running) .....	1100 watts
Refrigerator (1/6 HP. starting) .....	850 watts
Freezer (1/4 HP. starting) .....	1050 watts
Furnace (1/6 HP. starting) .....	850 watts
Kitchen Lights .....	200 watts
Living Room Lights .....	500 watts
Bathroom Lights .....	150 watts
Other Lights .....	150 watts
Total .....	4850 watts

**D. Starting Electric Motors:** The following table is based on average load conditions. Allow at least 20% extra for hard starting motors or difficult starting conditions such as compressors or pressure pumps.

Motor HP Rating	Approx. "Running" Watts	Split Phase Motors	Capacitor Start Motors	Repulsion Induction Motors
1/6	275	2050	850	600
1/4	400	2400	1050	850
1/3	450	2700	1350	975
1/2	600	3600	1800	1300
3/4	850	--	2600	1900
1	1100	--	3300	2500

The following amperes are produced at 115 volts and at 230 volts for the wattages shown for various sizes of generators.

WATTS	AMPERES at 115 volts	AMPERES at 230 volts
1000	8.7	--
2000	17.4	--
2500	21.7	10.9
3500	30.4	15.2
5000	43.4	21.2
6500	56.5	28.3
10000	87.0	43.4

Most fractional horsepower motors take about the same amount of current to run them whether they are of the Repulsion-Induction (RI), Capacitor (Cap.), or Split-Phase (SP) type. The following chart shows the approximate current required to start and run various types and sizes of 115 volt 60 cycle motors under average load conditions.

H. P.	RUNNING Amperes All Types	"STARTING" AMPERES		
		S. P.	Cap.	R. I.
1/6	3.2	16 to 22	6 to 13	5 to 8
1/4	4.5	22 to 32	9 to 18	7 to 12
1/3	5.2	36 to 35	10 to 21	8 to 17
1/2	7.2	Not Made	14 to 29	11 to 18
1	13	Not Made	26 to 52	20 to 33

**E. Refer to Chart below for commonly used equipment and wattage used.** These figures are given for reference purposes and estimating only. If in doubt as to motor size consult the motor nameplate.

LOAD	USUAL MOTOR SIZE H.P. or WATTAGE
Lights	Refer to Bulbs
Furnace Stoker Motor	1/4 H.P.
Furnace Blower Motor	1/4 H.P.
Furnace Circular Motor	1/6 H.P.
Furnace Oil Burner	1/6 H.P.
Refrigerator	1/4 H.P.
Food Freezer	1/4 to 1/3 H.P.
Coffee Maker	1200
Toaster	1200
Skillet	1200
Mixer	125
Water Pump	1/4 to 1 H.P.
Other Pumps	1/4 to 1 H.P.
Electric Range	5000 - 10000
Electric Water Heater	1000 - 5000
Electric Clothes Dryer	4000 - 1/6
Washing Machine	1/6 to 1/2 H.P.
Dishwasher	1/6 H.P.
Television	200 to 500
Radio	50
Kitchen Ventilator	125
Air Conditioner	1/6 and up H.P.
Bathroom Heater	250 and up H.P.
Electric Iron	600 to 1500
Elevator	1/2 and up H.P.
Braoder	100 and up H.P.
Milking Machine	1/3 and up H.P.
Milk Cooler	1/2 and up H.P.
Milk Pump	1/4 and up H.P.
Cream Separator	1/6 and up H.P.
Barn Fan	1/6 and up H.P.
Barn Cleaner	2 and up H.P.
Feed Conveyor	1/2 and up H.P.

## VOLTAGE VARIANCE

A sensitive governor on the tractor engine that drives the PTO at a consistent RPM will allow for little voltage variance; also, the electrical load connected to the alternator. The following chart shows voltage variances.

PTO-20, 20,000 Watts			PTO-15, 15,000 Watts		
Watts	Volts	Freq.	Watts	Volts	Freq.
0	260	61	0	260	61
3000	258	61-	3000	256	60+
6000	256	60+	6000	252	60
7000	252	60	7000	246	60-
12000	246	60-	12000	238	59
15000	238	59	15000	230	58+
18000	232	59-			
20000	230	58+			

**DISTRIBUTED BY**

**Forney INDUSTRIES, INC.**

P. O. BOX 563 FORT COLLINS, COLORADO 80521  
REGINA, SASK. CANADA





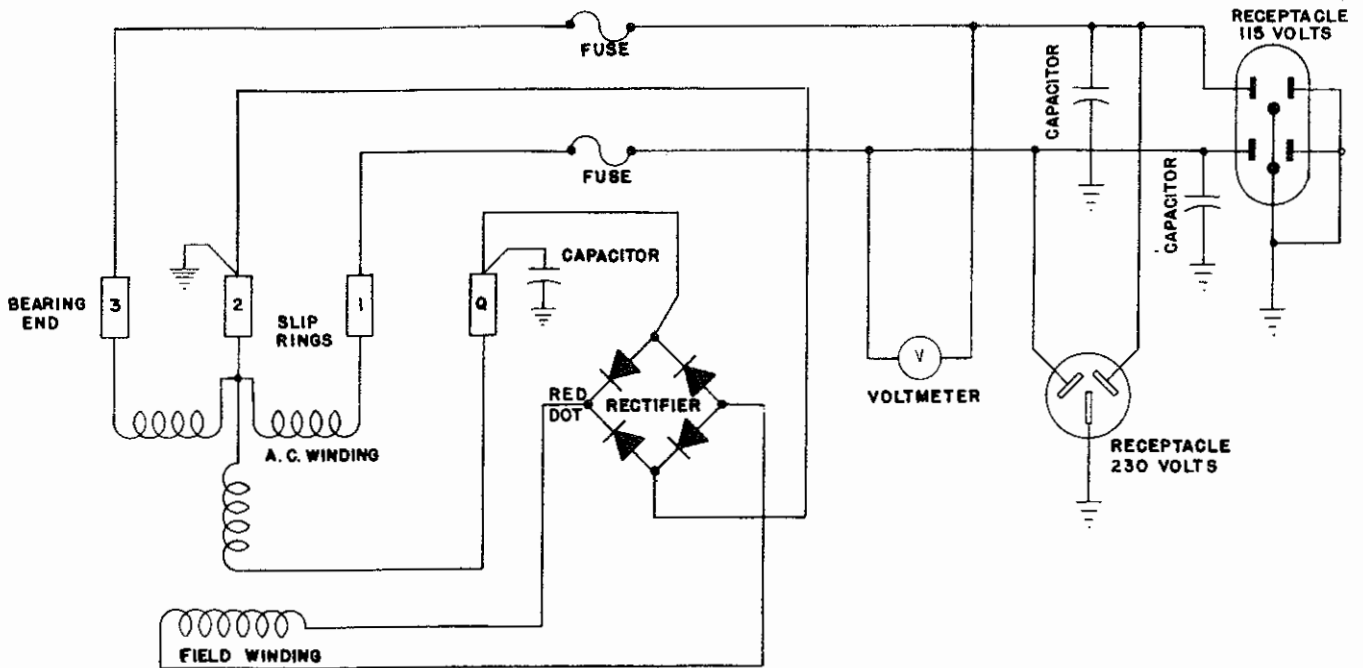

### PARTS LIST

Ref. No.	Part No.	Description	Qty.	Ref. No.	Part No.	Description	Qty.
1	51101	Field Sh. cap screw	4	31	52559	Brush holder spacer	2
2	480	Field Shell lockwasher	4	32	44342	Machine screw	4
3	20137	Sleeve	1	33	24981	A.C. Brush	12
4	54804	End Bracket	1	34	41387-6	Ground strap	1
5	46912	Oil Seal	1	35	41221	Condenser	1
6	46913	Bearing	1	36	54734	Field shell & Bracket	1
7	44318	Bearing Retain. Plate	1	37	54754	Base assembly	1
8	479	Bear. Ret. L-washer	3	38	48178	Hex head screw	2
9	45633	Bear. Ret. Screw	3	39	636	Lockwasher (split type)	2
10	52497-1	Armature	1	40	40746	Brush holder screw	28
11	43473	Pole shoe assembly	2	41	4637	Machine screw	4
12	43474	Pole shoe retainer	2	42	484	Lockwasher	4
13	54819	Field coil assembly	1	43	456	Hex Nut	4
14	54819-1	Field Coil assembly	1	44	40552	Lockwasher (fan)	1
15	50215	Bearing	1	45	23404	Fan assembly	1
18	54790	Eye bolt	1	46	21867	Flat washer (fan)	1
19	1744	Nut	3	47	20039	L-washer (fan) split type	1
20	5113	Hex nut	9	48	9549	Hex nut (fan)	1
21	6376	Lockwasher (split type)	9	49	23634	End Cover	1
22	23599	Machine screw	1	50	56194	Control box (only)	1
23	21977	Machine screw	4	51	52490	Voltmeter	1
24	23500	Brush holders	2	52	48343	Receptacle	1
25	53949	Q ring brush	2	53	24749	Duplex receptacle	1
26	53976	Rectifier	1	54	56206	Condensers	2
27	53806	Cap screw	8	55	48406	Fuse base	1
28	23532	Fiber spacers	14	56	48469	Fuse	2
29	23500-2	A.C. brush holders	12	57	43743	Ground Lug	1
30	53975	Brush holder mtg. plate	6	60	6402	Machine screw	2

Any parts required for gas engine portion of the unit should be obtained from the local engine manufacturer's service station.

# PTO (POWER TAKE OFF) ALTERNATOR

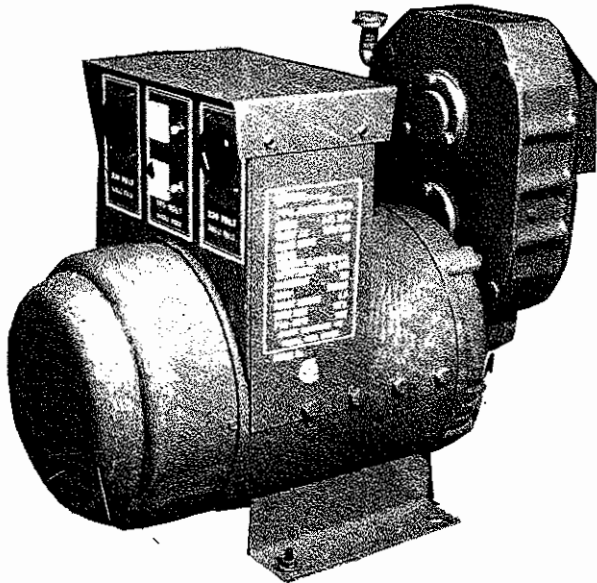

**PERHAPS** you have experienced power failure at some time. If so, we don't have to remind you that the losses can be heavy. Practically everything stops when power is cut off - no lights, water, heat, coolers, freezers, refrigerators, power tools, feeders, milkers, radio and TV. In a moment's time a tornado, hurricane, blizzard, flood or lightning could plunge your whole operation into costly confusion - unless you have auxiliary power. Fasten this unit on a two-wheel trailer, attach the power take-off on your tractor and you are ready for any job any place, whether there is power or not.

## PORTABLE or STANDBY

### MOST COMMONLY USED MODELS

**PTO-15-1 | PTO-15-3 | PTO-20-1 | PTO-20-3**  
**Cat.#600-0 | Cat.#601-0 | Cat.#605-0 | Cat.#606-0**

### FEATURES

- \* 3600 RPM Armature
- \* 540 RPM Tractor PTO Speed
- \* Precision Gear Drive
- \* Oil Bath Gear Case
- \* Pre-lubed Sealed Bearings
- \* Burn-out Proof
- \* Cool Running
- \* Minimum Frequency Variation
- \* No fuses or Breakers
- \* Calibrated Voltmeter
- \* Compact and Light Weight
- \* Long Brush Life
- \* Radio and TV Static Checked
- \* 230/115 Volt Outlets
- \* DC Windings
- \* No Drip Insulation
- \* Minimum Maintenance
- \* Full One-Year Warranty

**ALL MODELS** have the same precision gear drive and the alternators are all burn-out proof. 3600 RPM is a plus factor for easier motor starting due to the inertia factor. Quality design holds temperature rise to approximately 50% of what NEMA standards allow. It is an excellent unit for use as a standby power source because of the minimum frequency variation and radio and TV interference has been suppressed.

**AUXILIARY POWER** designed for both 115 volt and 230 volt, 60 cycle in both single phase and three phase. 520 RPM at the gear box PTO produces 3600 RPM on the armature. The control tower is equipped with a volt meter facing the shaft for easy reading and setting of the engine speed desired. The reverse side has a rain-type cover protecting the two 115 volt outlets and the one 230 volt outlet.

**3600 RPM ARMATURE** provides greater motor starting ability through the inertia factor. The rotating armature also provides portability by less weight (same watts - smaller package) compared to an 1800 RPM rotating fields type unit. The rotating armature type has proven to be a more rugged and durable unit.

**540 RPM TRACTOR PTO SPEED** - The gear reduction makes it possible for almost any tractor to drive this unit as the 540 RPM is a very low requirement. The engine powering the unit needs only the capability of producing 2 HP per 1000 watts to assure proper operation.

## GEAR DRIVE NOT CHAIN

The precision machined helical gears are incased in rugged line-bored cast iron and run in an oil bath requiring only regular automotive type gear oil. This means quieter operation, less breakage, no links to replace, etc.

## CONTROL PANEL

When the powering source maintains the proper RPM required, the unit will have little or no frequency variation (that is, using an engine equipped with a sensitive governor). The calibrated voltmeter is located facing forward so the operator can see the meter and adjust the powering engine properly. The same control panel is equipped with one 230 volt and two 115 volt outlets, sheltered with a covering door.

## ALTERNATOR

The case is aligned-grain, rolled, welded and honed. The armature rotates inside stationary fields on pre-lubricated sealed ball bearings. The insulation is drip-proof and is of a class rating allowing up to 130° C. temperature rise by NEMA standards. Designed to give protection lasting as long as the alternator lasts. The collapsible fields provide for positive overload protection (burn-out proof) and stops electrical output and is considered a "plus" over fuses and circuit breakers. Collapsible fields reduce continued overloading to a minimum creating longer life of the alternator. They have DC windings. Capacitors are included on both load circuits and exciter circuit to minimize interference on radio and TV. There are four commutator rings and four brushes per ring and held by a nonmetallic brush holder. Tests have shown up to 5000 hours of brush life, so brush wear is at a minimum.

## STANDBY POWER

For standby power on 230 volts, either the 230 volt outlet can be used or, if the local codes require, direct connection can be made to leads inside the control box. To even increase its versatility, the alternators can be made portable by either skid or trailer mounting the unit thereby making it possible to move it to any place that you need electric power.

## GENERATOR WELDER POSSIBLE

We have good portable welders that can be used with the PTO Alternators as their source of power by plugging them into the 230 volt outlet. The 110 volt outlets are rated at 15 amps for lights, electric drills, etc.

For those who want the most complete and economical portable power-welder unit, begin with the Forney PTO Power Alternator, then add a Forney Model F Welder, plus a Forney Acetylene Outfit and Forney Accessory Kits; place all on a two-wheel trailer, attach the power take-off to your tractor and you are ready for any job any place, whether there is power or not.

## WARRANTY

Within one year of your purchase date, your PTO unit fails to operate satisfactorily because of defects in workmanship or material, authorized repair will be made at our Fort Collins, Colorado factory, or by an authorized Factory Representative.

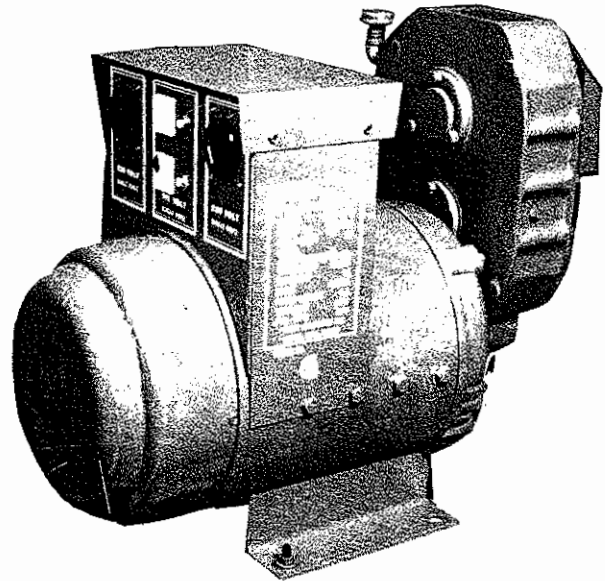

### SPECIFICATIONS of available PTO alternators

PTO-15 ALTERNATOR, single phase, 12,000 continuous, 15,000 intermittent, approx. 19,500 surge, starts 7.5 H.P. motor, runs 10-12 H.P. (25-35 H.P. tractor)

PTO-15 ALTERNATOR, three phase, 12,000 continuous, 15,000 intermittent, approx. 19,500 surge, starts 7.5 H.P. motor, runs 10-12 H.P. (25-35 H.P. tractor)

PTO-20 ALTERNATOR, single phase, 15,000 continuous, 20,000 intermittent, approx. 25,000 surge, starts 10 H.P. motor, runs 13-16 H.P. (30-40 H.P. tractor)

PTO-20 ALTERNATOR, three phase, 15,000 continuous, 20,000 intermittent, approx. 25,000 surge, starts 10 H.P. motor, runs 13-16 H.P. (30-40 H.P. tractor)

PTO-30 ALTERNATOR, single phase, 25,000 continuous, 30,000 intermittent, approx. 40,000 surge, starts 13 H.P. runs 20 H.P. 1800 R.P.M., 540 R.P.M. (50 H.P. tractor)

PTO-30 ALTERNATOR, three phase, 25,000 continuous, 30,000 watts intermittent, approx. 40,000 surge, starts 13 H.P. runs 20 H.P. 1800 R.P.M., 540 R.P.M. (50 H.P. tractor)

PTO-45 ALTERNATOR, single phase, 37,000 continuous, 45,000 intermittent, approx. 60,000 surge, starts 20 HP.P. load, runs 30 H.P. 1800 R.P.M., 1000 R.P.M. on PTO, (tractor 75 H.P.)

PTO-45 ALTERNATOR, three phase, 37,000 continuous, 45,000 intermittent, approx. 60,000 surge, starts 20 H.P. load, runs 30 H.P. 1800 R.P.M., 1000 R.P.M. on PTO (tractor 75 H.P.)

PTO-60 ALTERNATOR, single phase, 50,000 continuous, 60,000 intermittent, approx. 80,000 surge, starts 26 H.P., runs 40 H.P. 1800 R.P.M., 1000 R.P.M. on PTO, (tractor 100 H.P.)

PTO-60 ALTERNATOR, three phase, 50,000 continuous, 60,000 intermittent, approx. 80,000 surge, starts 26 H.P., runs 40 H.P. 1800 R.P.M., 1000 R.P.M. on PTO, (tractor 100 H.P.)

## OPTIONAL ACCESSORIES

### LINE TRANSFER SWITCHES

Required with any self-powered or tractor-operated non-automatic alternator which is hooked into wiring system connected to hi-line. Change from hi-line to alternator power, or from alternator back to hi-line by simply throwing the lever.

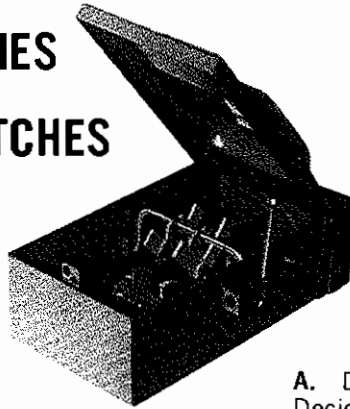

This is a heavy-duty, lift front, safety box. Non-fused, 100 Amp rating for three (3) wire 120/240 volt AC power. 13" long, 7" wide, 4" deep. General Electric design, Type G, Model I, 3SN Pole. Easy to install, foolproof connection. 200 amp boxes also available.

### PTO DRIVE SHAFT



You'll need this PTO Drive Shaft to connect your Tractor to your PTO (Power Take-Off) Alternator. This is a fine quality, heavy-duty telescoping drive shaft with double universal joints. The telescoping drive shaft is 4 ft. long and extends to 6 ft. This shaft size is 1 inch with slip over shaft of 1 3/8 inches. The protective shield is 3 inches in diameter and telescopes to coincide with the drive shaft. Complete with 1 3/8 inch x 6 inch spline to couple the power take-off to the universal joint. Universal joints are made from "forged steel".

### SHAFT ADAPTERS

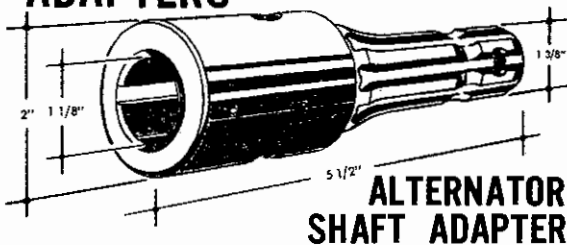

**ALTERNATOR  
SHAFT ADAPTER**

This PTO Alternator Adapter is an adapter with a fully splined male and a keyed female end to be used to attach to your PTO Alternator shaft and then to a PTO Shaft or Tumbler. The size of the male spline and female end is as shown on the drawing above.

### DRIVE SHAFT ADAPTER (REDUCER)

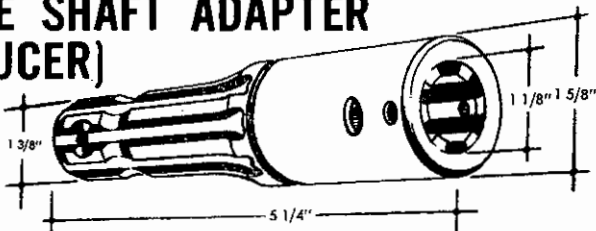

This PTO Drive Shaft Adapter or Reducer is available for the customer who desires an adapter or reducer which is fully splined to work with a tumbler bar he may already have. The size of the male and female spline ends are as shown above.

## HOW TO DETERMINE THE PROPER ALTERNATOR and EQUIPMENT

The size of the alternator: In choosing the equipment best suited to the customer's needs, the following steps should all be carefully considered:

**A.** Determine the size of the alternator that is needed. Decide which electrical equipment is to be kept running in the event of a power failure. This may include the entire load or it may be decided that certain heavy loads will not be used during the powerline outage; for example, the air conditioner, water heater, and electric range. However, since the purchase of a stand-by alternator for the home may be a "once in a lifetime" purchase, it is unwise to choose a model which will not provide reasonable comforts and convenience during a power outage. It is particularly important to carefully consider the electrical power required to start the electric motors which are to be used during the emergency. All motors require much more current to start them than it does to run them after they are started as shown in the table on page 4.

**B.** The emergency power source must be the same voltage, frequency and phase as the normal power line. If all of the circuits are to be transferred to the emergency standby alternator, the manual transfer switch should have an ampere rating equal to that of the service entrance. If only part of the circuits are to be transferred, it must have an ampere rating equal to or larger than the combined ratings of the branch circuits which are to be transferred. For example, if three circuits rated at 20 amperes were to be transferred in a 115/230 Volt system, neither main branch exceeds 60 amperes so a Transfer Switch with a rating of 60 amperes is large enough.

**C.** To determine the Alternator capacity required for the standby load:

1. List the "starting" watts for all "automatic" appliances as refrigerators, freezers and furnaces.
2. List the wattage of all lights and heating devices, such as toasters and percolators.
3. List the "running watts" of all motors which will be turned on manually, such as sump pumps or pressure pumps, and left turned on while other "automatic" appliances such as refrigerator and furnace blower will be used.
4. Determine the sum of 1, 2 and 3 above.
5. Recheck the motors in Item # 3 to be sure that none of the motors require more power for starting than can be supplied by the alternator.

**EXAMPLE:** A suburban home has the following requirements for minimum standby service: A 1 HP. deep well jet pump which will be turned on manually during standby service, a refrigerator (1/6 HP. cap.) and furnace blower (1/6 HP. cap.) which operated automatically, 200 watts of light in the kitchen, 500 watts in the living room, 150 watts in the bathroom and 150 watts in other locations:



Pump (1 HP. running) .....	1100 watts
Refrigerator (1/ 6 HP. starting) .....	850 watts
Freezer (1/ 4 HP. starting) .....	1050 watts
Furnace (1/ 6 HP. starting).....	850 watts
Kitchen Lights.....	200 watts
Living Room Lights.....	500 watts
Bathroom Lights.....	150 watts
Other Lights.....	150 watts
Total .....	4850 watts

**D. Starting Electric Motors:** The following table is based on average load conditions. Allow at least 20% extra for hard starting motors or difficult starting conditions such as compressors or pressure pumps.

Motor HP Rating	Approx. "Running" Watts	Split Phase Motors	Capacitor Start Motors	Repulsion Induction Motors
1/6	275	2050	850	600
1/4	400	2400	1050	850
1/3	450	2700	1350	975
1/2	600	3600	1800	1300
3/4	850	--	2600	1900
1	1100	--	3300	2500

The following amperes are produced at 115 volts and at 230 volts for the wattages shown for various sizes of generators.

WATTS	AMPERES at 115 volts	AMPERES at 230 volts
1000	8.7	--
2000	17.4	--
2500	21.7	10.9
3500	30.4	15.2
5000	43.4	21.2
6500	56.5	28.3
10000	87.0	43.4

Most fractional horsepower motors take about the same amount of current to run them whether they are of the Repulsion-Induction (RI), Capacitor (Cap.), or Split-Phase (SP) type. The following chart shows the approximate current required to start and run various types and sizes of 115 volt 60 cycle motors under average load conditions.

H. P.	RUNNING Amperes All Types	"STARTING" AMPERES		
		S. P.	Cap.	R. I.
1/6	3.2	16 to 22	6 to 13	5 to 8
1/4	4.5	22 to 32	9 to 18	7 to 12
1/3	5.2	36 to 35	10 to 21	8 to 17
1/2	7.2	Not Made	14 to 29	11 to 18
1	13	Not Made	26 to 52	20 to 33

**E. Refer to Chart below for commonly used equipment and wattage used.** These figures are given for reference purposes and estimating only. If in doubt as to motor size consult the motor nameplate.

LOAD	USUAL MOTOR SIZE H.P. or WATTAGE
Lights	Refer to Bulbs
Furnace Staker Motor	1/4 H.P.
Furnace Blower Motor	1/4 H.P.
Furnace Circular Motor	1/6 H.P.
Furnace Oil Burner	1/6 H.P.
Refrigerator	1/4 H.P.
Food Freezer	1/4 to 1/3 H.P.
Coffee Maker	1200
Toaster	1200
Skillet	1200
Mixer	125
Water Pump	1/4 to 1 H.P.
Other Pumps	1/4 to 1 H.P.
Electric Range	5000 - 10000
Electric Water Heater	1000 - 5000
Electric Clothes Dryer	4000 - 1/6
Washing Machine	1/6 to 1/2 H.P.
Dishwasher	1/6 H.P.
Television	200 to 500
Radio	50
Kitchen Ventilator	125
Air Conditioner	1/6 and up H.P.
Bathroom Heater	250 and up H.P.
Electric Iron	600 to 1500
Elevator	1/2 and up H.P.
Braoder	100 and up H.P.
Milking Mochine	1/3 and up H.P.
Milk Cooler	1/2 and up H.P.
Milk Pump	1/4 and up H.P.
Cream Separator	1/6 and up H.P.
Barn Fan	1/6 and up H.P.
Barn Cleaner	2 and up H.P.
Feed Canveyor	1/2 and up H.P.

## VOLTAGE VARIANCE

A sensitive governor on the tractor engine that drives the PTO at a consistent RPM will allow for little voltage variance; also, the electrical load connected to the alternator. The following chart shows voltage variances.

PTO-20, 20,000 Watts			PTO-15, 15,000 Watts		
Watts	Volts	Freq.	Watts	Volts	Freq.
0	260	61	0	260	61
3000	258	61-	3000	256	60+
6000	256	60+	6000	252	60
7000	252	60	7000	246	60-
12000	246	60-	12000	238	59
15000	238	59	15000	230	58+
18000	232	59-			
20000	230	58+			

**DISTRIBUTED BY**

**Forney INDUSTRIES, INC.**

P. O. BOX 563 FORT COLLINS, COLORADO 80521  
REGINA, SASK. CANADA



# WINCO GENERATOR PLANT MODEL P15PTOF-3/D

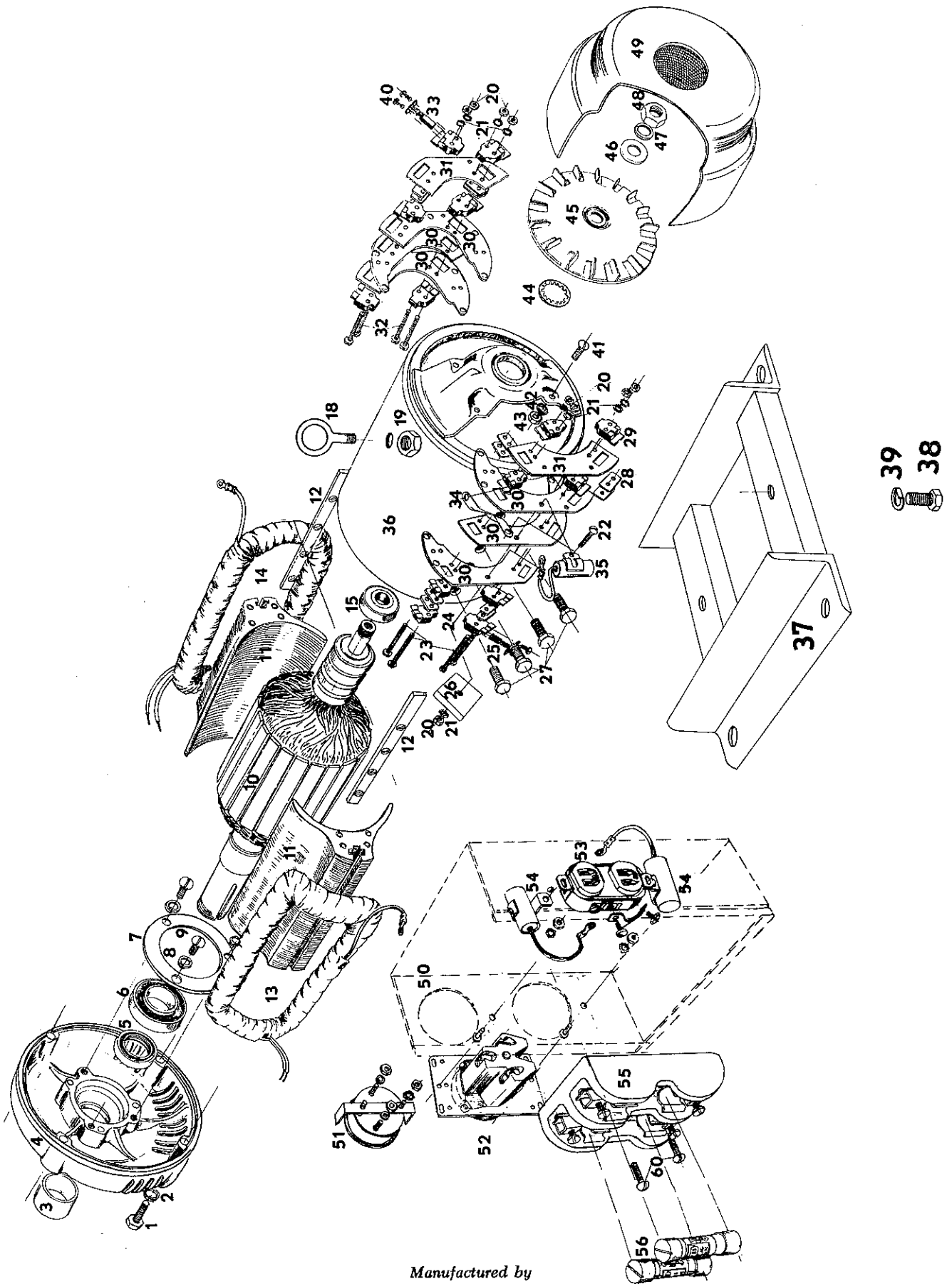

Manufactured by

## **WINCO**

Division of Dyna Technology, Inc.

East Seventh at Division / P. O. Box 3263 / Phone (712) 252-1821 / SIOUX CITY, IOWA 51102

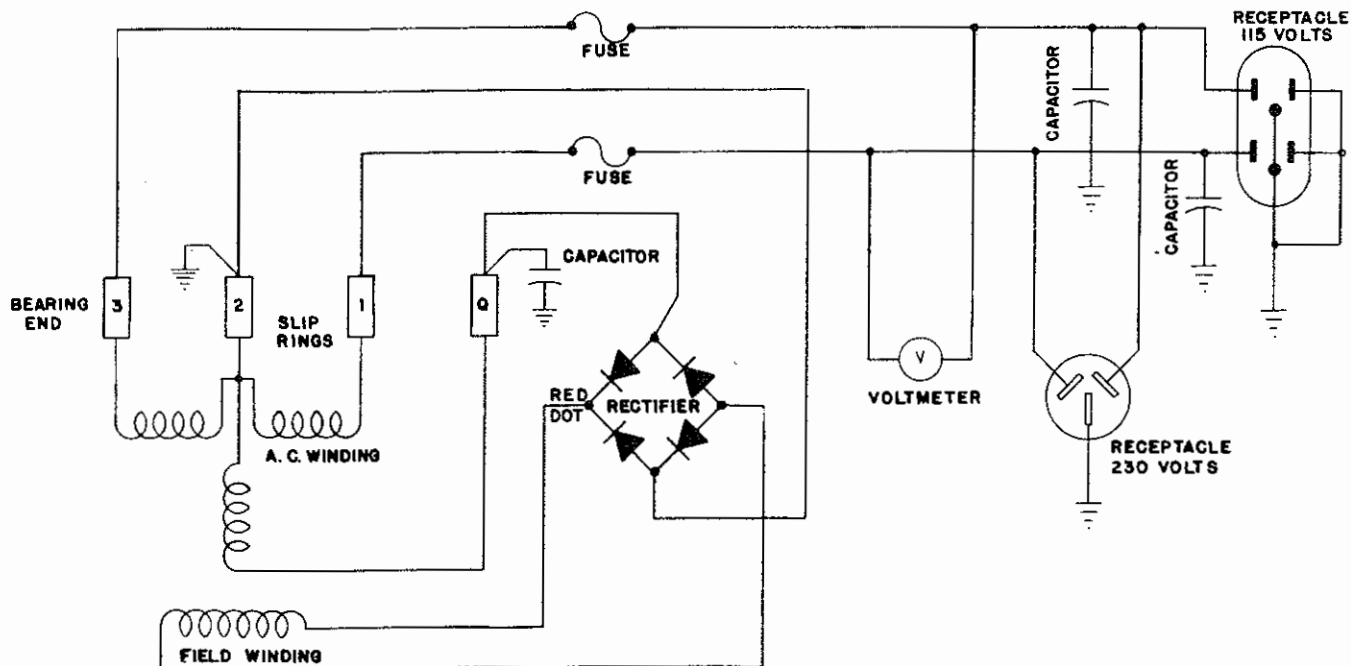

### PARTS LIST

Ref. No.	Part No.	Description	Qty.	Ref. No.	Part No.	Description	Qty.
1	51101	Field Sh. cap screw	4	31	52559	Brush holder spacer	2
2	480	Field Shell lockwasher	4	32	44342	Machine screw	4
3	20137	Sleeve	1	33	24981	A.C. Brush	12
4	54804	End Bracket	1	34	41387-6	Ground strap	1
5	46912	Oil Seal	1	35	41221	Condenser	1
6	46913	Bearing	1	36	54734	Field shell & Bracket	1
7	44318	Bearing Retain. Plate	1	37	54754	Base assembly	1
8	479	Bear. Ret. L-washer	3	38	48178	Hex head screw	2
9	45633	Bear. Ret. Screw	3	39	636	Lockwasher (split type)	2
10	52497-1	Armature	1	40	40746	Brush holder screw	28
11	43473	Pole shoe assembly	2	41	4637	Machine screw	4
12	43474	Pole shoe retainer	2	42	484	Lockwasher	4
13	54819	Field coil assembly	1	43	456	Hex Nut	4
14	54819-1	Field Coil assembly	1	44	40552	Lockwasher (fan)	1
15	50215	Bearing	1	45	23404	Fan assembly	1
18	54790	Eye bolt	1	46	21867	Flat washer (fan)	1
19	1744	Nut	3	47	20039	L-washer (fan) split type	1
20	5113	Hex nut	9	48	9549	Hex nut (fan)	1
21	6376	Lockwasher (split type)	9	49	23634	End Cover	1
22	23599	Machine screw	1	50	56194	Control box (only)	1
23	21977	Machine screw	4	51	52490	Voltmeter	1
24	23500	Brush holders	2	52	48343	Receptacle	1
25	53949	Q ring brush	2	53	24749	Duplex receptacle	1
26	53976	Rectifier	1	54	56206	Condensers	2
27	53806	Cap screw	8	55	48406	Fuse base	1
28	23532	Fiber spacers	14	56	48469	Fuse	2
29	23500-2	A.C. brush holders	12	57	43743	Ground Lug	1
30	53975	Brush holder mtg. plate	6	60	6402	Machine screw	2

Any parts required for gas engine portion of the unit should be obtained from the local engine manufacturer's service station.

Customer support.txt

This info is all I can find on the pto generators. we had a 15 and a 20kw model. It is entirely possible that a 30kva model was special order. The generator parts were made by winco. (see inclosed sheet) I don't know if they are still in business. You might try a web search. And if you haven't already a search for "pto generator" might turn up something. I think all the wiring was similar between the models. Good Luck!

Ed Stevens-Hoeltzner  
Repair Technician

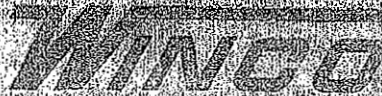

Division of DYNA TECHNOLOGY, INC.

East Seventh at Division St

P.O. Box 3263

Sioux City Iowa 51102

May 5, 1976

MAY 16 1976

- 12PPTO-3/E20 - 12KW (your 15KW) 115/230-volt, 1 phase, PTO TRACTOR DRIVEN GENERATOR  
1 #51559 lifting eye installed on above NET \$ [REDACTED]
- 12PPTO-4 - 12KW (your 15KW) 120/208-volt, 3 phase PTO TRACTOR DRIVEN GENERATOR  
1 #51559 lifting eye installed on above NET \$ [REDACTED]
- 15PPTO-3/E37 - 15KW (your 20KW) 115/230-volt, 1 phase PTO TRACTOR DRIVEN GENERATOR  
1 #51559 lifting eye installed on above NET \$ [REDACTED]
- 15PPTO-4/E23 - 15KW (your 20KW) 120/208-volt, 3 phase PTO TRACTOR DRIVEN GENERATOR  
1 #51559 lifting eye installed on above NET \$ [REDACTED]
- 30PPTOC-3/B4 - 30KW, 115/230-volt, 1 phase NET \$ [REDACTED]
- 35PPTOC-4/B1 - 35KW, 120/208-volt, 3 phase NET \$ [REDACTED]
- 35PPTOC-17/B - 35KW, 115/230-volt, 3 phase NET \$ [REDACTED]

I have also enclosed for your information a standard price sheet on the other models. Your discount on these models would be [REDACTED] percent plus applicable quantity discount.

# TRACTOR- DRIVEN GENERATOR

ASSEMBLY INSTRUCTIONS  
OPERATING INSTRUCTIONS  
SERVICE INFORMATION

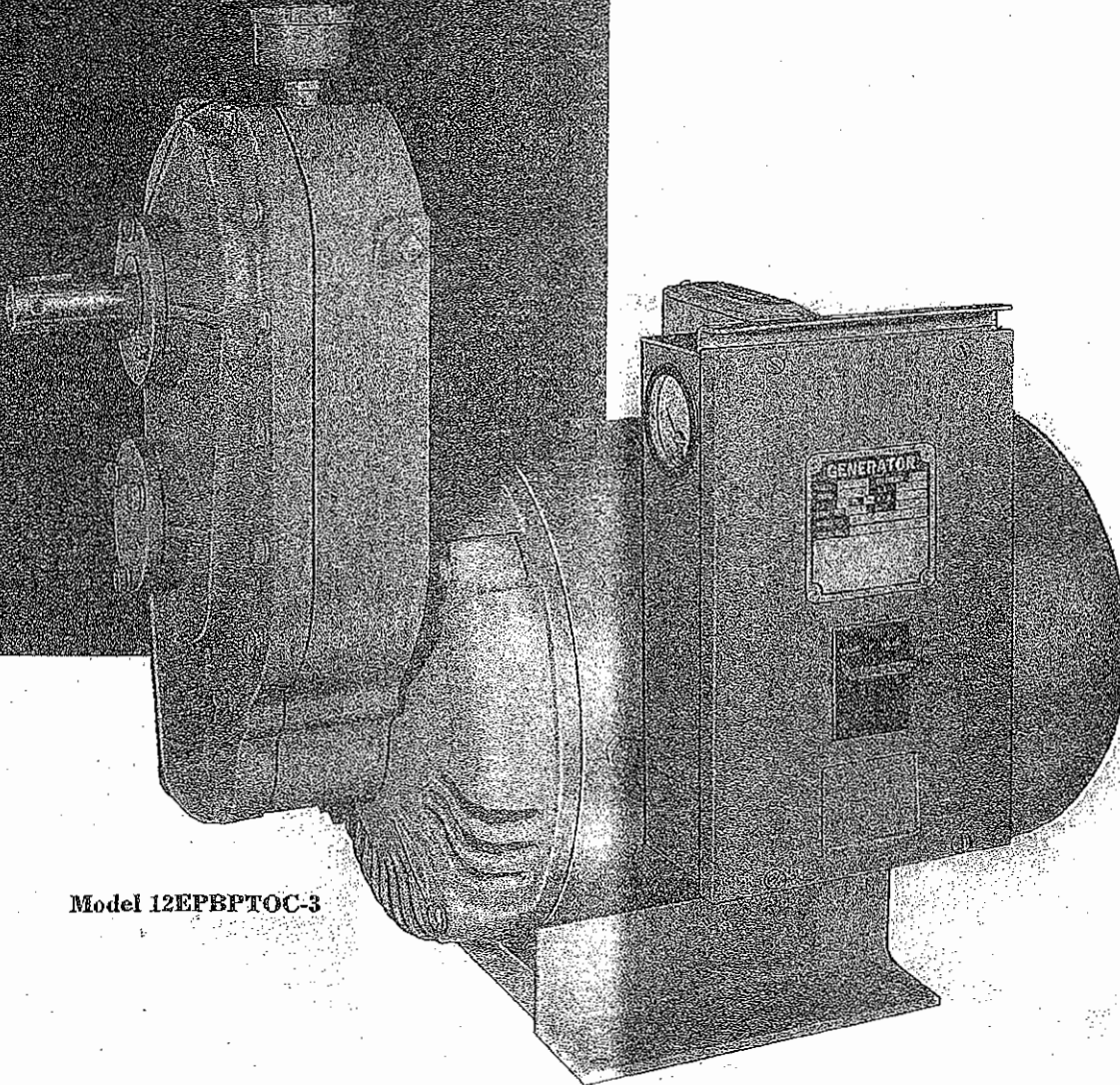

Model 12EPBPTOC-3

Write the model number and serial number of the generator in the spaces below and save this book for future references. Be sure to give these numbers if corresponding about or ordering parts for the generator.

GENERATOR MODEL \_\_\_\_\_ SERIAL \_\_\_\_\_

## INTRODUCTION

BEFORE ANY POWER-TAKE-OFF TRACTOR-DRIVEN GENERATOR IS SHIPPED FROM THE FACTORY IT IS THOROUGHLY CHECKED FOR PEAK PERFORMANCE. The generator has been run long enough for the brushes to seat properly so that good electrical contact is made between them and the slip rings. With the generator fully loaded, the voltage, current, and frequency have been carefully checked. NO UNIT IS SHIPPED UNLESS IT PRODUCES ITS FULL RATED CAPACITY AND PASSES OTHER RIGID INSPECTION TESTS.

If upon installation a new generator does not work properly, check all of the electrical connections and the generator speed before concluding that the generator is not performing satisfactorily. When unpacking the machine, be sure to inspect it carefully to see that no damage occurred in transit. If damage is noted, notify the transportation company immediately and

have them write the nature of the damage on the freight bill, so that a claim can be filed if necessary.

**NOTICE REGARDING GEAR CASE LUBRICANT.** The train of gears in the gear box has a step-up ratio of 6.65:1. A speed of 540 RPM is required to drive the generator at 3600 RPM. The tractor must be capable of delivering approximately 2.2 H.P. per 1000 watts of electrical output of the generator. THERE IS NO OIL IN THE GEAR CASE when the unit is shipped. A quart of gear lube (Mobilube 80-90) is supplied in a separate can. Remove the breather cap from the top of the gear case and the "OIL LEVEL" plug from the back of the gear case. Pour oil into the gear case (about 1 quart) until it comes out of the "OIL Level" note; then install the plug and the breather cap. No further lubrication is required on the unit.

## OPTIONAL ACCESSORIES

### SHIELDED UNIVERSAL 48" TELESCOPING PIN COUPLING TUMBLING BAR

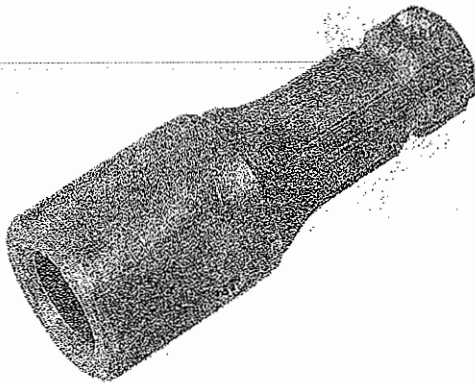
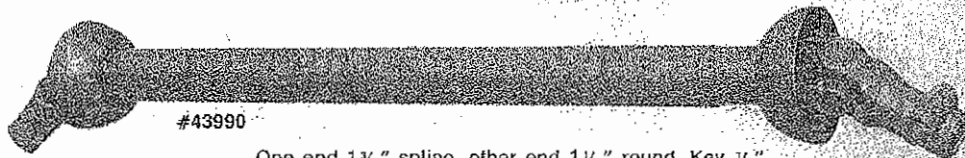

### SPLINED ADAPTER

#44804  
For power-take-off.

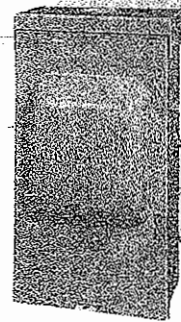

### MANUAL TRANSFER SWITCHES

These hand operated line transfer switches are enclosed and unfused. These switches have rain-tight cabinets and may be used outdoors as well as indoors. Available in 100 and 200 amp. ratings.

## LOCATION

The P.T.O. unit can be mounted on a trailer for portability or it can be bolted to a slab of concrete 2 feet square and 3 inches thick in a permanent installation.

For best service there are several factors which should be taken into consideration:

1. **Moisture:** All electrical equipment should be protected from excessive moisture. Failure to do so will result in deterioration of the insulation and will result in short circuits and grounds. If the unit is to be left in the open, it should be covered with a piece of canvas to keep out water and dust.
2. **Dirt:** Foreign materials such as dust, sand, lint and abrasive particles have a tendency to cause excessive wear to bearings, gears, brushes, etc. These materials will also clog the ventilation holes and cause excessive heating. It is, therefore, important that the unit be protected as much as possible to extend its useful life.

## CONNECTING THE LOAD

These generators are supplied with various control boxes including units equipped with receptacles, fuses, and generators with the lead wires terminating in a knockout type box.

### UNITS EQUIPPED WITH FUSES AND RECEPTACLES

If your particular generator is a single-phase generator equipped with fuses and receptacles, connections can be made to the manual transfer switch by using a 3-wire cord connected to the switch and a 50 Amp. range-type male plug on the end of the cord so it may be plugged in directly to the receptacle provided on the control box. This type of unit also includes a duplex grounding type 115 volt receptacle.

If this generator is to be permanently installed, we recommend a seal-tite greenfield connector be connected from the transfer switch through the knockouts provided in the control box. The 2 hot leads should be connected to the terminals provided on the bottom of the fuse block. The ground lead should be connected to the ground terminal on the side of the control box.

### THREE-PHASE GENERATORS SUPPLIED WITH FUSES

This type of generator should be connected to the manual transfer switch with a seal-tite greenfield cable. Knockouts are provided in the manual transfer switch and in the generator control box for connecting the cable.

The 3 hot leads of the 120/208 volt, 3-phase generator should be connected to the 3 terminals provided on the bottom of the fuse block. The ground lead should be connected to the terminal provided on the side of the control box.

## UNITS EQUIPPED WITH CIRCUIT BREAKERS

Single-phase generators equipped with circuit breakers should be connected to the manual transfer panel with seal-tite greenfield cable and the 2 hot leads should be connected to the terminals provided on the bottom of the circuit breaker. The ground lead should be connected to the terminal provided on the side of the generator control box.

## GENERATOR SUPPLIED WITH JUNCTION BOX ONLY

On single-phase generators the generator leads should be connected to the manual transfer switch in the following manner:

The 2 black lead wires identified as G-1 should be connected together and spliced to one of the hot leads from the transfer switch. The 2 white lead wires identified as G-2 and G-3 should be spliced together and connected to the ground wire from the transfer switch. The 2 black leads identified as G-4 should be spliced together and connected to the other hot lead from the transfer switch.

On 3-phase, 120/208 volt generators, the 2 black lead wires identified as G-1 should be connected together and spliced to one of the hot lead wires from the transfer switch. The 2 black leads identified as G-2 should be spliced together and connected to one of the hot leads from the transfer switch. The 2 black leads identified as G-3 should be spliced together and connected to one of the hot leads of the transfer switch. The 2 white leads identified as G-4 should be spliced together and connected to the ground of the transfer switch.

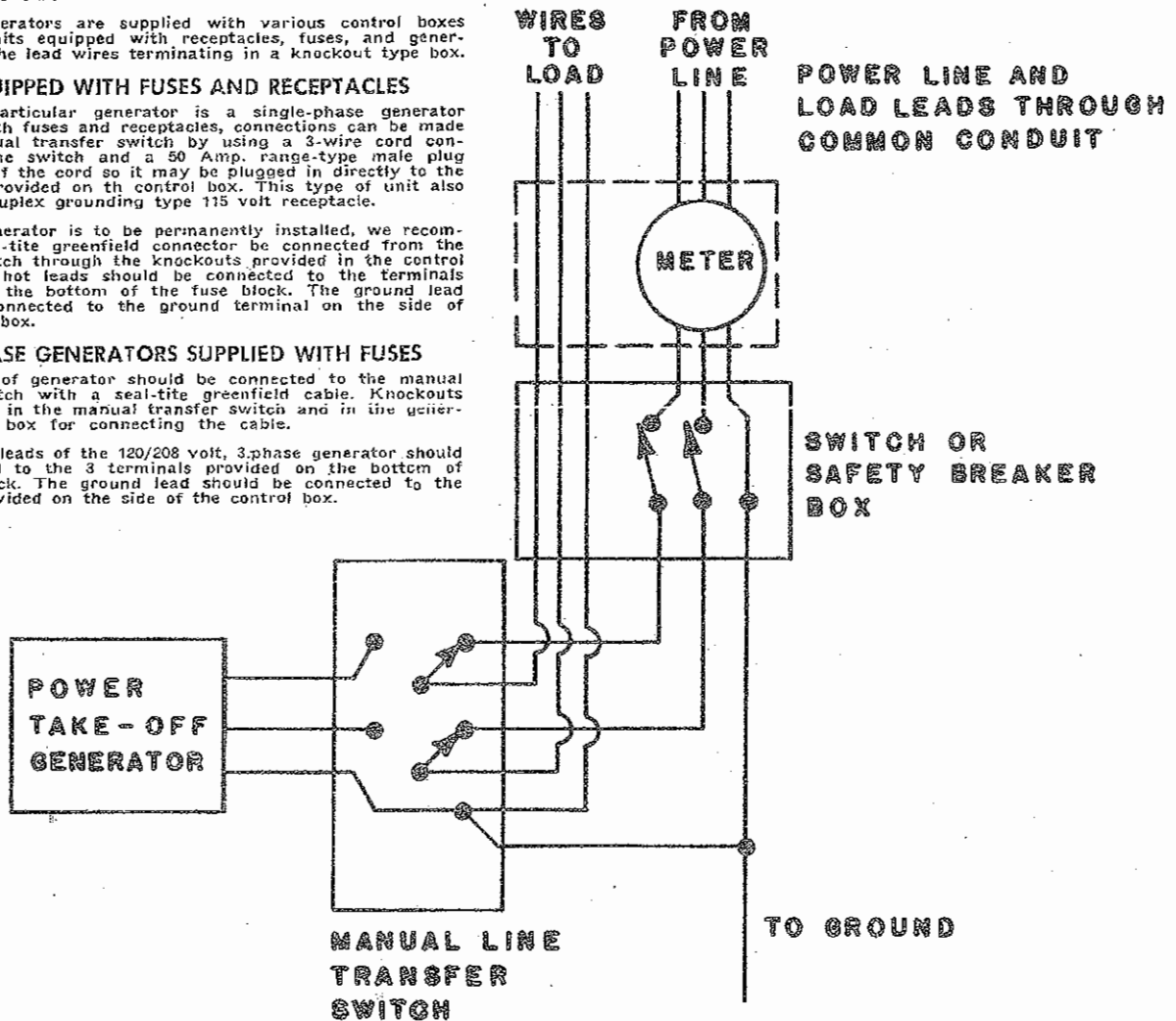

# TYPICAL SINGLE PHASE INSTALLATION WITH UNSWITCHED NEUTRAL

Figure 1

## OPERATION

These generators must be driven by the power-take-off of a tractor. A heavy-duty tumbling bar is required with a 1 3/4" 6 spline on one end and a 1 1/4" diameter female coupling on the other end. (This is Part No. 43990). If the operator wishes to use his own tumbling bar, an adapter is available (Part No. 44804) which converts the 1 1/4" diameter round shaft on the gear case to a 1 3/4" 6 spline fitting. In the interest of safety,

**BE SURE THE ENTIRE POWER-TAKE-OFF IS PROPERLY EQUIPPED WITH SAFETY SHIELDS.**

Using suitable means, connect the unit to the tractor and adjust the throttle setting of the tractor to produce a voltage of approximately 260 volts with no load connected. With a sensitive governor on the tractor engine, the voltage will vary approximately as shown in the following table depending on the electrical load connected to the generator. Each of the 115 volt circuits will produce half the voltage shown,

Capacity % of Rated	Voltage	Frequency (Cycles per Second)
0	260	61
20	256	60+
40	252	60
60	246	60
80	238	59
100	230	58+

As the load is varied from no-load to full-load it may be necessary to adjust the throttle of the tractor.

## VOLTMETER

Two different types of voltmeters are used on the tractor generators. One meter is graduated from 0-300 volts and also is color-coded in red and green. The tractor speed should be adjusted to keep the needle of the voltmeter in the green area when the generator is carrying its normal load. The other meter is not color-coded, however, is a 0-300 voltmeter and the throttle should be adjusted so the meter reads approximately 230 volts under normal load.

## FUSES

If your particular single-phase generator includes fuses, they are 60 Amp. Super-Lag renewable fuses. The generator is supplied with 10 additional fuse links which are located in an envelope in the bottom of the generator control box.

## CAUTION

Any generator which is installed for standby or emergency power must be equipped with a suitable double-throw switch for use when the power line fails. The switch transfers the load from the power line to the generator.

When the transfer switch is thrown to the "power line", the standby generator is not connected to either the load or the power line. When the switch is thrown to the "standby" side, the generator is connected to the load but the load is disconnected from the power line. Consequently, no electricity produced by the generator can feed back to the power line where it would be hazardous to line repairmen. (See Figure 2).

## USE OF ELECTRIC MOTORS

Electric motors require MUCH MORE current (amperes) to start them than to run them. Some motors, particularly cheap SPLIT-PHASE motors are VERY hard to start and require 5 to 7 times as much current to start them as to run them. CAPACITOR motors are easier to start and usually require 2

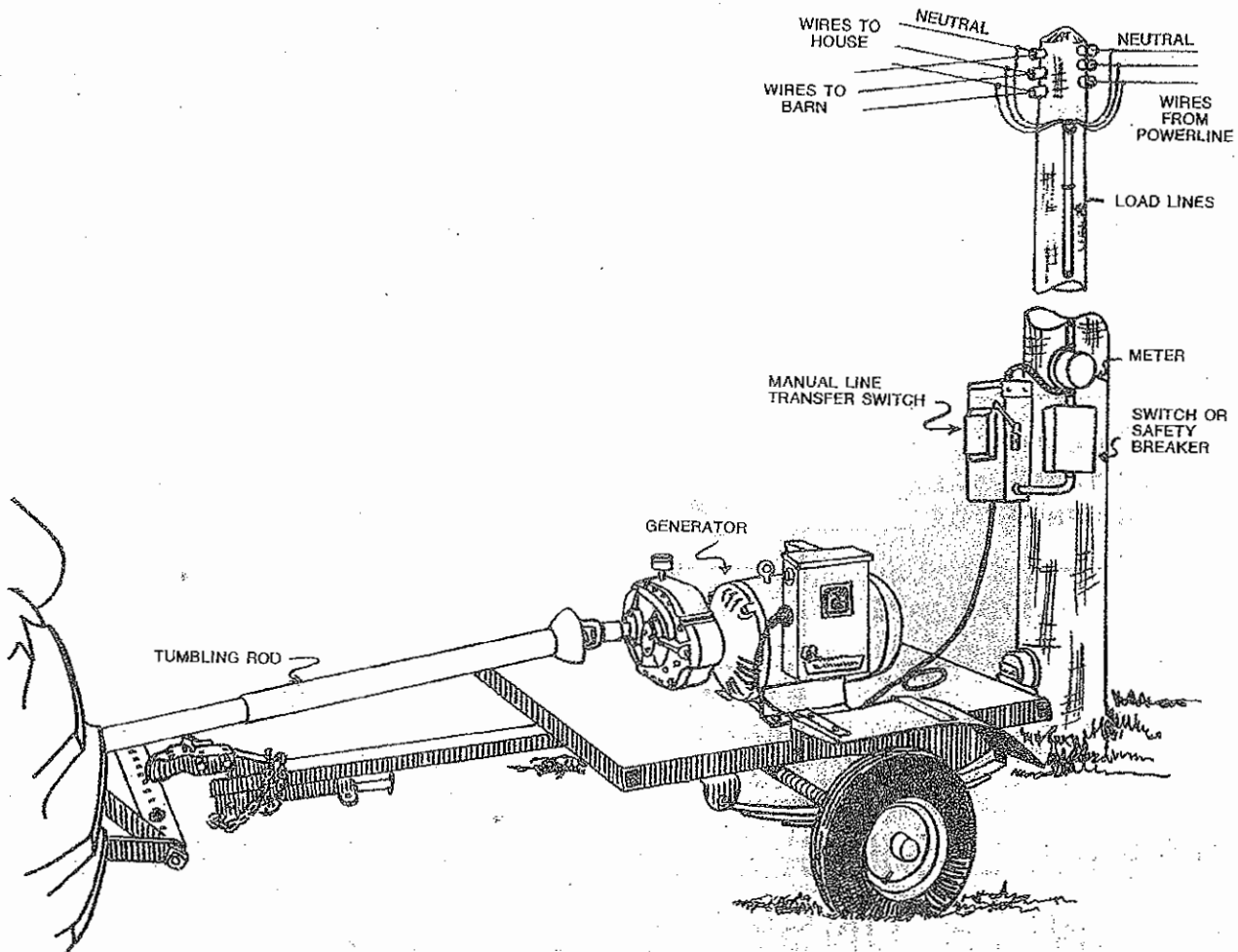

Figure 2



to 4 times as much current to start them as to run them. REPULSION INDUCTION MOTORS are the easiest to start and usually require 1/2 to 2 1/2 times as much to start them as to run them. Refer to the nameplate of the generator for the ampere rating of your unit.

Most fractional horsepower motors take about the same amount of current to run them whether they are of the Repulsion-Induction (R.I.), Capacitor (Cap.), or Split-Phase (SP) type. The chart below shows the approximate current required to start and run various types and sizes of 115 volt 60 cycle motors under average load conditions.

H. P.	RUNNING Amperes ALL TYPES	"STARTING" AMPERES		
		S.P.	Cap.	R.I.
1/6	3.2	16 to 22	6 to 13	5 to 8
1/4	4.5	22 to 32	9 to 18	7 to 12
1/3	5.2	26 to 35	10 to 21	8 to 17
1/2	7.2	Not Made	14 to 29	11 to 18
1	13	Not Made	26 to 52	20 to 33

The figures given above are for average load such as a blower or fan. If the electric motor is connected to a HARD STARTING load such as an air compressor, it will require MORE starting current. If it is connected to a LIGHT LOAD, or no load such as a power saw, it will require LESS starting current. The exact requirement will also vary with the brand or design of the motor.

For 230 volt motors the "running" current is half as much as shown for the 115 volt motors of the same size. Some dual voltage 115/230 volt motors are difficult to start on 230 volts when driven by engine-generators and can be started more easily when connected to operate on 115 volts. This is particularly true of "capacitor start—induction run" motors. Sometimes a 230 volt motor which cannot be started on the 230 volt circuit of a 115/230 volt generator can be started on a 115 volt circuit and then quickly switched to the 230 volt circuit after it is started. This can be done in applications where the motor is manually controlled and is started under "no load" conditions.

A self-excited generator responds differently to severe overloading than a transformer connected to a power line. To illustrate, suppose that a 230 volt 5 H.P. "Capacitor Start—Induction Run" motor is connected to a small transformer with a maximum rating of 2500 watts and then to a generator of 2500 watts capacity. The transformer would not be able to supply enough power to bring the motor up to operating speed but would be very severely overloaded and probably would burn out in a short time. The motor might also be damaged. When this motor is connected to a self-excited 2500 watt generator, its output voltage drops to practically zero. Also, the excitor voltage drops to practically zero. Thus, there is virtually no load on the generator or the engine, and no harm is done to either. Under these conditions the motor may revolve a few times when it is first turned on, and then stop.

On the other hand, suppose an electric motor that requires just a little more output than the generator can produce is connected to it. It will run but will not reach a high enough speed for the centrifugal switch to disconnect the starting winding. The generator output voltage, instead of being 115, may drop to 70 or 80 volts. Running the generator under these conditions may result in burning out the generator armature as well as the motor windings.

Because the heavy surge of current required for starting motors is required for only an instant, the generator will not be damaged if it can bring the motor up to speed in a few seconds of time. If difficulty is experienced in starting motors, turn off all other electrical loads and if possible reduce the load on the electric motor.

## MAINTENANCE

**Brushes**—Check the brushes for wear after about 1000 hours of operation and every few hundred hours of operation thereafter. They should be replaced when worn down to 1/2 inch. Whenever replacing brushes or removing them to do service work, remove one brush at a time and put the screws back into the brush holder to hold the lead wire terminals in place so there will be no difficulty in connecting the wires to the correct positions.

**Commutator**—A commutator in good condition has a glossy finish and is brownish in color. If it gets greasy, rough or dirty, it may be cleaned with very fine sandpaper. (Do not use emery cloth).

**Bearings**—All ball bearings used in these generators are packed with grease before assembly—no further greasing is required. If they become rough or worn they should be replaced.

**Oil Seal**—If oil is dripping from the ventilating slots on the end bracket nearest the gear case, then the oil seal must be replaced. To replace this seal proceed as follows:

1. Drain oil by removing drain plug.
2. Remove the 3 nuts holding the gear case to the end bracket and slide the gear case off the 3 studs. Set the gear case aside.
3. Remove the 1/2" hex nut, the lockwasher, pinion and key.
4. Remove the end cover, fan nut, and fan from the brush end of the generator.
5. Remove the 4 bolts holding the generator end bracket to the field shell; pry the end bracket loose and slide it off. Extreme care should be taken at this point so as not to pull the armature out along with the end bracket.
6. Remove the 3 machine screws on the inside of the end bracket and the retainer plate can be removed. The bearing will now drop out.
7. Pull out the bushing and punch out the old oil seal.
8. Lubricate the new oil seal and spacer with Lubriplate or cup grease and insert the seal and spacer with the leather lip of the seal toward the inside of the gear case.
9. Put in the bearing and retainer plate and reassemble the unit. Put oil back in the gear case.

**Armature**—In case it is necessary to remove the armature, proceed as follows:

1. Follow Steps 1-5 under Maintenance—Oil Seal.
2. Remove brushes as described under Maintenance—Brushes.
3. Slide armature out.

**Gear Case Oil**—Check the gear case oil level before each use and replenish as needed with Mobilube 80-90. The oil should be changed every 6 months unless operating under adverse weather conditions. In the winter, moisture will condense in the gear case and in the summer there is the problem of dust and dirt so the oil must be changed more often.

## LOCATING TROUBLE

If the generator does not operate properly, check the circuit breaker or fuses if included on the generator. If the circuit breaker is tripped, reduce the load and reset the breaker. If the fuses are blown, replace the element with a new element provided with this generator. Check the conditions under which the generator has been operating and if necessary, make the electrical tests as outlined below:

1. Sometimes a generator won't produce electricity when it is started even though it was working satisfactorily when it was turned off. This is usually caused by inadequate contact between the brushes and slip rings and occurs most often on new generators or generators in which new brushes have been installed and not completely seated. Under certain conditions it can happen after the brushes are seated. The problem can easily be corrected by cleaning the commutator surface with a brush seating stone or very fine sandpaper.

2. Is the speed correct? Check the speed with a tachometer or frequency meter. If the generator cannot be kept up to its rated capacity, the tractor is too small (it takes about 2.2 HP per 1000 watts of generated electrical power), is not working properly, or the governor is not sensitive enough to hold the speed constant over a wide load range. The speed of the generators can be checked easily with a tachometer by removing the cover from the end of the generator and applying the tachometer.

3. Is the generator overloaded? Check the nameplate for maximum safe load and if uncertain about the amount of load, check it with an ammeter and voltmeter.

4. Is the location satisfactory? See "Location" regarding sufficient ventilation if the generator is being operated in an enclosed area. If it is being operated under dusty or dirty conditions be sure all ventilation holes and slots are cleaned periodically.

5. Is the commutation satisfactory? With the generator in operation, notice whether there is an appreciable arcing or sparking at the brushes. See the article on brushes under "Maintenance".

6. A voltmeter is used to indicate that the generator is producing electricity. If the voltmeter does not register, check the output with a light bulb or another meter before deciding that the generator is not performing as it should.

7. If no output is obtained at the outlet receptacles or output wires, disconnect all electrical loads and connect a voltmeter directly to the A.C. Brushes as shown in Figure 3. If no voltmeter is available, use any ordinary small 115 volt bulb or on 230 volt generators check each of the 115 volt circuits with the bulb.

If normal voltage is obtained at the A.C. Brushes but not at the output terminals, there must be an open circuit between these points.

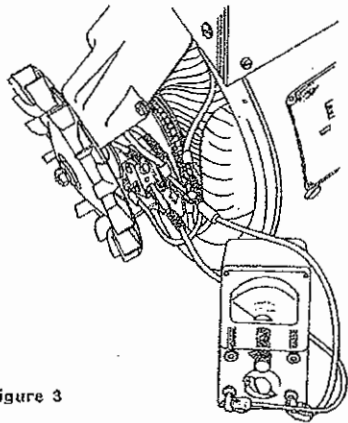
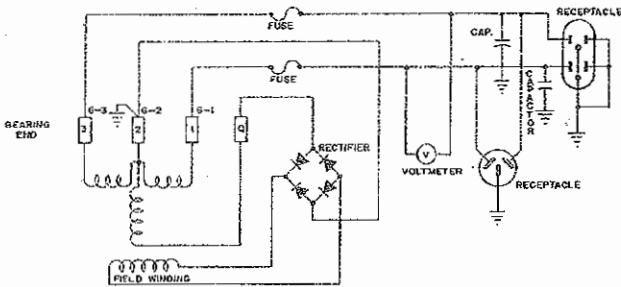

Figure 3

8. If no A.C. voltage is obtained at the A.C. Brushes, check the excitation voltage.

**A. Electronic Excitation**

On generators which include electronic excitation, check the voltage by measuring between the grounded brush and Q brush (refer to Figure 4). This should give a reading of approximately 120 volts A.C. The electronic excitation is accomplished by an extra coil wound on the armature at 90° from the A.C. coils. This is called a quadrature winding. One end of this winding is connected to the slip ring #2 which is grounded and the other end is connected to slip ring Q (the ring farthest from the bearing end of the generator).



**ELECTRONIC EXCITATION**

Figure 4

These 2 rings are connected to a bridge rectifier which changes the A.C. to D.C. The D.C. is then conducted to the shunt field and provides the excitation to the generator. If no A.C. voltage is obtained at the Q brush, disconnect the wire leading from the rectifier module. If the voltage now builds up, the rectifier is defective and should be replaced. If it does not build up, the quadrature winding is defective and the armature should be replaced.

If A.C. voltage is obtained from the Q brush to ground, then check the D.C. output of the rectifier module. Use a D.C. voltmeter with the positive lead wire on the rectifier module connection identified by the red dot and the negative lead wire on ground. This should show a reading of approximately 100 volts D.C. If you do not obtain this voltage, the rectifier is defective and should be replaced. A possible reason for the rectifier going bad is a grounded field coil. The grounded field coil can be checked as described in 9A.

**B. Commutator Excitation**

On units equipped with a commutator, the excitation can be checked with a D.C. voltmeter connected to the D.C. brushes (positive lead to insulated brush, negative lead to grounded brush). The excitation voltage should be approximately 54-65 volts. If this is not obtained, check the field coils for grounds or opens and repair or replace as necessary.

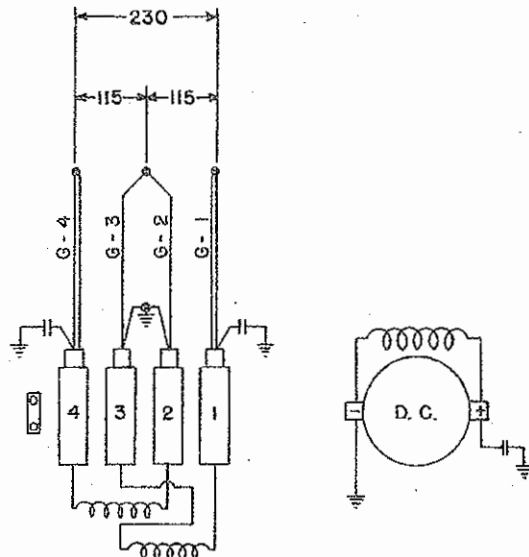

**COMMUTATOR EXCITATION**

Figure 5

**9. Checking Field Coils**

A. Disconnect the field leads and with an ohmmeter check each field coil terminal to the generator frame to be sure the coils are not grounded. If a high voltage insulation tester is available, check from the lead wires of the coil to the frame at 1100 volts. If a field coil shows a ground, it should be repaired or replaced.

B. Using an ohmmeter, check for continuity of the field coils by hooking the ohmmeter leads to the field coil leads. If an open exists, examine the connection between the field coils and the connection from the winding of the field coils to the lead wires. Repair the open or replace the field coil as required.

10. A. One side of the A.C. circuit is "grounded" to the generator frame. The other side is said to be "live" or "hot". Any short-circuit between the "hot" side of either circuit and any metal part of the generator will result in a grounded condition which prevents the generator from producing electricity. Carefully inspect all "hot" wires and terminals for evidence of a grounded condition.

B. There are 2 A.C. filter capacitors located in the control box or on the brush rack. If either of these capacitors become shorted, it will short out the A.C. of the generator. The capacitor should be disconnected and the lead wire insulated, however, the generator can be used until a replacement capacitor is obtained. These capacitors are to reduce radio interference.

11. If these tests have not located the trouble, re-move the armature and have it teste for opens, shorts, and grounds on a growler (see Figure 6).

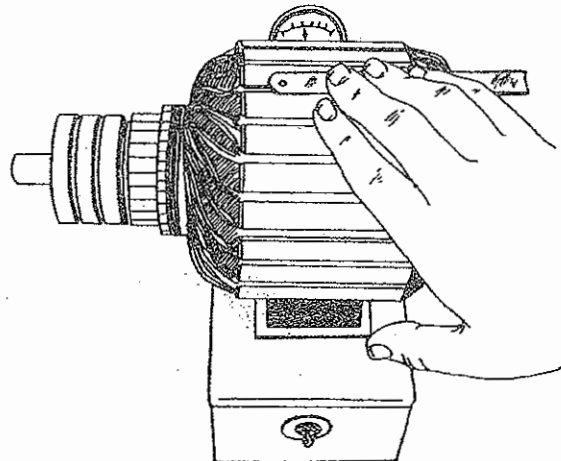
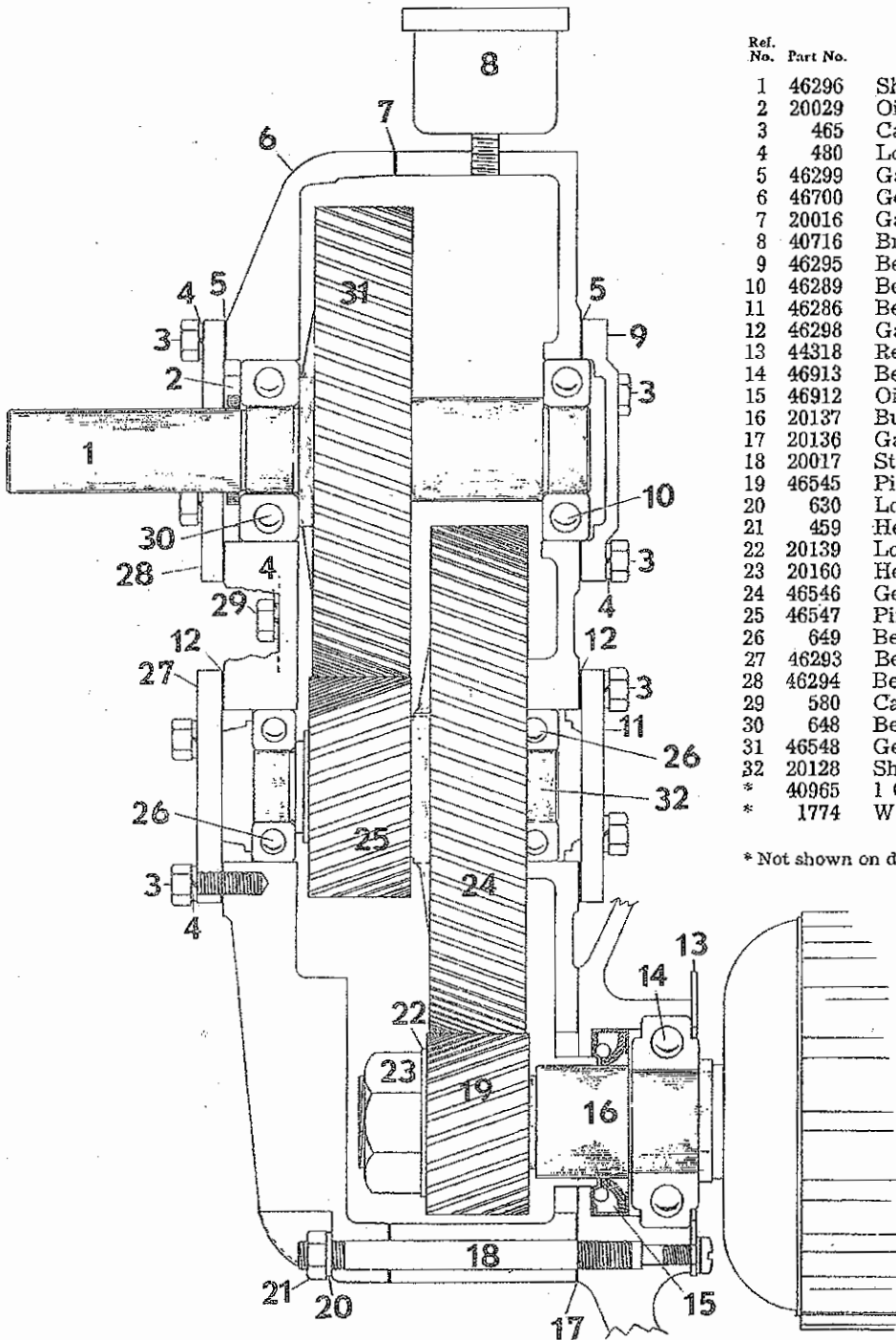

Figure 6

**GEAR CASE FOR TRACTOR DRIVEN PTO GENERATORS  
MODELS ENDING IN /B AND /C**



Ref. No.	Part No.	DESCRIPTION	Quantity
1	46296	Shaft	1
2	20029	Oil Seal	1
3	465	Cap Screw 5/16 - 18 x 7/8	12
4	480	Lockwasher 5/16"	24
5	46299	Gasket	2
6	46700	Gear Case & Cover	1
7	20016	Gasket	1
8	40716	Breather	1
9	46295	Bearing Retainer	1
10	46289	Bearing	1
11	46286	Bearing Retainer	1
12	46298	Gasket	2
13	44318	Retainer Plate	1
14	46913	Bearing	1
15	46912	Oil Seal	1
16	20137	Bushing	1
17	20136	Gasket	1
18	20017	Stud	3
19	46545	Pinion	1
20	630	Lockwasher	3
21	459	Hex Nut 3/8"	3
22	20139	Lockwasher	1
23	20160	Hex Jam Nut	1
24	46546	Gear	1
25	46547	Pinion	1
26	649	Bearing	2
27	46293	Bearing Retainer	1
28	46294	Bearing Retainer	1
29	580	Cap Screw 5/16 - 18 x 1 1/4	12
30	648	Bearing	1
31	46548	Gear	1
32	20128	Shaft	1
*	40965	1 Qt. Gear Oil	1
*	1774	Woodruff Key #15 (1/4 x 1")	4

\* Not shown on drawing.

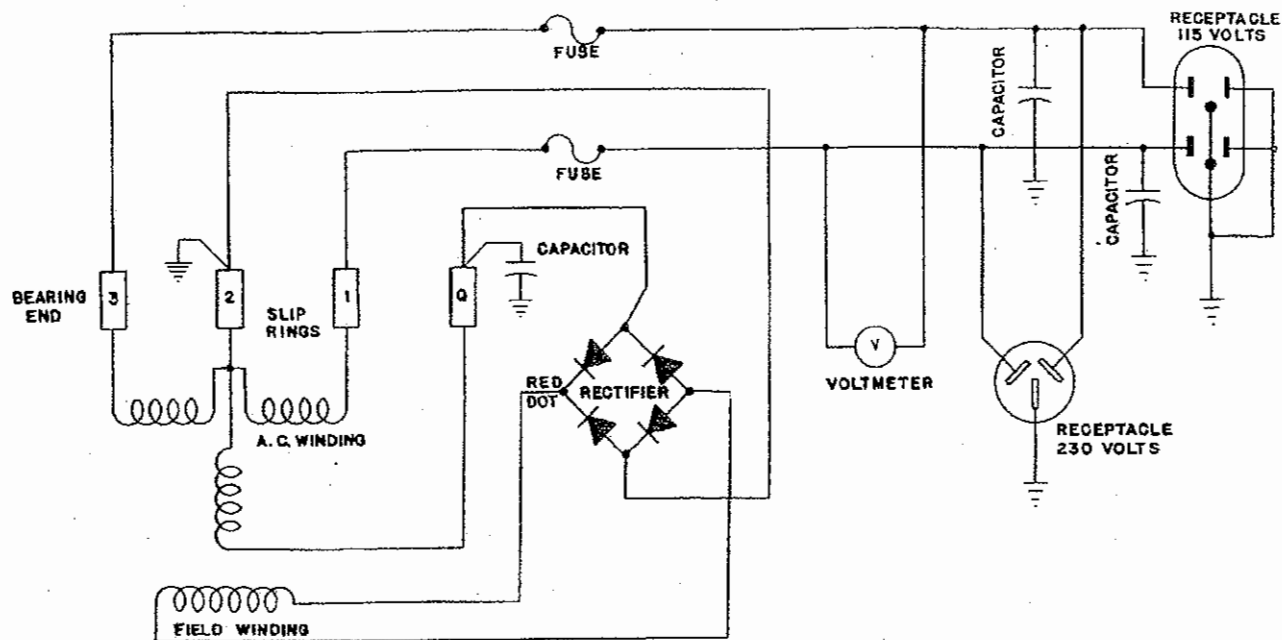

### PARTS LIST

Ref. No.	Part No.	Description	Qty.	Ref. No.	Part No.	Description	Qty.
1	51101	Field Sh. cap screw	4	31	52559	Brush holder spacer	2
2	480	Field Shell lockwasher	4	32	44342	Machine screw	4
3	20137	Sleeve	1	33	24981	A.C. Brush	12
4	54804	End Bracket	1	34	41387-6	Ground strap	1
5	46912	Oil Seal	1	35	41221	Condenser	1
6	46913	Bearing	1	36	54734	Field shell & Bracket	1
7	44318	Bearing Retain. Plate	1	37	54754	Base assembly	1
8	479	Bear. Ret. L-washer	3	38	48178	Hex head screw	2
9	45633	Bear. Ret. Screw	3	39	636	Lockwasher (split type)	2
10	52497-1	Armature	1	40	40746	Brush holder screw	28
11	43473	Pole shoe assembly	2	41	4637	Machine screw	4
12	43474	Pole shoe retainer	2	42	484	Lockwasher	4
13	54819	Field coil assembly	1	43	456	Hex Nut	4
14	54819-1	Field Coil assembly	1	44	40552	Lockwasher (fan)	1
15	50215	Bearing	1	45	23404	Fan assembly	1
18	54790	Eye bolt	1	46	21867	Flat washer (fan)	1
19	1744	Nut	3	47	20039	L-washer (fan) split type	1
20	5113	Hex nut	9	48	9549	Hex nut (fan)	1
21	6376	Lockwasher (split type)	9	49	23634	End Cover	1
22	23599	Machine screw	1	50	56194	Control box (only)	1
23	21977	Machine screw	4	51	52490	Voltmeter	1
24	23500	Brush holders	2	52	48343	Receptacle	1
25	53949	Q ring brush	2	53	24749	Duplex receptacle	1
26	53976	Rectifier	1	54	56206	Condensers	2
27	53806	Cap screw	8	55	48406	Fuse base	1
28	23532	Fiber spacers	14	56	48469	Fuse	2
29	23500-2	A.C. brush holders	12	57	43743	Ground Lug	1
30	53975	Brush holder mtg. plate	6	60	6402	Machine screw	2

Any parts required for gas engine portion of the unit should be obtained from the local engine manufacturer's service station.

INSTALLATION AND OPERATION INSTRUCTIONS  
TRACTOR PTO ALTERNATOR  
15,000 and 20,000 WATT MODELS

The Forney Tractor PTO Alternator is a rugged heavy-duty electric Alternator Power Plant that will provide an economical and dependable source of electrical power either as a portable or standby unit.

This Alternator is designed to be driven by a tractor power take off or other engine sources of power that will provide 520 RPM to the Alternator gear box.

**IMPORTANT.** Each Alternator is carefully inspected at the factory and a run in is made until the brushes are satisfactorily seated. The unit then is carefully checked for the correct output under the average operating conditions. No Alternator is shipped unless it produces its full rated capacity, nor until it has passed all rigid inspection tests. Before operating be sure that all installation requirements and instructions are followed. If for some reason the Alternator does not work properly, be sure to check all electrical connections that may have come loose in transit, and tractor PTO speed before reaching the conclusion the Alternator is not performing satisfactorily.

Before operation is attempted, OIL MUST BE CHECKED IN THE GEAR CASE. Oil should be checked periodically and if found low simply remove the breather from the top of the gear case and the oil level plug from the back of the gear case. Pour the oil (90 wt. gear lub) in the gear case, until it begins to come out of the oil level hole, then install both the plug and the breather cap.

The PTO Alternator should be securely bolted to a platform or a trailer. If your Power Unit is to be used strictly for standby and permanently located, a suitable base can be provided by pouring a block of concrete at least 8 inches thick and approximately 2 feet square and before the concrete is set bolts can be inserted into the concrete to match the alternator bolt-down holes. Another method would be to weld a platform out of heavy iron; for instance, railroad rails or heavy channel iron to provide a suitable base that is firmly anchored to the ground. If either of these methods of mounting is used, the Alternator is firmly anchored so it will not move during operation, and care should be taken that the tractor will not move or creep during operation. Wheel chocks, suitable brake on the wheels, or a connecting bar to the Alternator mount can be used.

If you intend to use the Alternator as a Portable unit, it should be mounted firmly to the bed of a trailer or skid. However, in either case there must be a tongue or towbar anchored firmly to the tractor and to the trailer or skid. This is to prevent the Alternator from separating from the tractor allowing the tumble bar to separate and become dangerous.

The Alternator should be installed in a location that allows the normal built-in fan cooling of the unit to operate satisfactorily. The amount of ventilation required will depend on several factors such as outdoor temperature, the size of the room (if mounted in a building with connection to tractor through a doorway or opening), the amount of natural air circulation in the room, and other heat-producing equipment that may be nearby. Under no circumstances should the temperature in the room or area be allowed to reach 120°F. If the unit is to be used outdoors, it is best if it can be located in a shady area or shade provided for it, but under no circumstances attempt to operate the unit with a box or tight enclosure around the unit.

Excessive dirty or dusty areas should be avoided in locating your Alternator only from the standpoint of the tendency for dirt or debris to clog the ventilation slots of the unit and thus cause excessive heating. Dirt in the air also causes excessive wear on the brushes and will contribute to higher maintenance costs.

The gear train in the gear box has a step-up ratio of 6.92 to 1 for both the 15,000 and 20,000 watt models. A speed of 520 RPM is required to drive the Alternator at 3600 RPM to deliver 60 cycle power. If the 15,000 watt Alternator is intended to be used for the 12,000 watt continuous duty level, a horsepower of 26.4 will be required to operate the Alternator. If it will be used utilizing the full 15,000 watts of intermittent power, a tractor horsepower of 33 will be required. If the 20,000 watt Alternator is intended to be used for the 15,000 watt continuous duty level, a horsepower of 30 will be required to operate the Alternator. If it will be used utilizing the full 20,000 watts of intermittent power, a tractor horsepower of 40 will be required.

All engines have a tendency to slow down when a load is applied. It is important that the governor on the engine is designed and adjusted to hold the speed nearly as constant as possible. The slight decrease in speed from the tractor along with the normal small voltage drop within the Alternator itself results in slightly lower voltage when the Alternator is loaded to its full capacity than when running idle. The resulting frequency variation has no appreciable effect on the operation of motors, lights, and most appliances; however, accurate timing devices such as clocks, will not keep perfect time when used on these Alternators.

The Forney Tractor PTO Alternator is equipped with a voltmeter for adjusting the speed and is also equipped in the same control box on the rear side with the rain-type cover outlet connections for both 230 volt and 115 volt. The Forney AC Arc Welders can be used from this Power Unit by plugging them into the 230 volt outlet in the control box. The two 110 volt outlets are rated 15 amps each for lights, electric drills, etc. If more capacity on 115 volts is needed, it is recommended that the load be wired directly to the connections inside the control box with suitable fusing or breakers supplied. Also if the unit is to be used for standby power on 230 volts, either the 230 volt plug-in can be used or if the local codes require again direct connection can be made to the leads inside the control box.

Adjust the throttle setting of the tractor to produce a voltage of approximately 260 volts on the voltmeter when no load is applied. With a good sensitive governor on the tractor engine the voltage will vary approximately as follows on the chart shown on page 3 and depending upon the electrical load connected to the Generator:

PTO-15, 15,000 Watts

PTO-20, 20,000 Watts

<u>Watts</u>	<u>Volts</u>	<u>Frequency</u>	<u>Watts</u>	<u>Volts</u>	<u>Frequency</u>
0	260	61	0	260	61
3000	256	60+	3000	258	61-
6000	252	60	6000	256	60+
7000	246	60-	7000	252	60
12000	238	59	12000	246	60-
15000	230	58+	15000	238	59
			18000	232	59-
			20000	230	58+

Low voltage may damage both the Alternator and any motors or appliances connected to it. Running an Alternator at excessively high speeds results in too high a voltage, which may also damage electrical devices connected to it. Excessively high speed may also cause damage to the armature winding. It is good practice to check the Alternator periodically to determine if the correct speed is used.

If the unit is to be used as standby power or emergency power, it must be equipped with some suitable disconnect to prevent damage to the Alternator when the powerline current from the power company is reinstated. A suitable double throw, double pole switch should be used when connecting to any loads normally served by a power company. This switch should be installed so that it completely disconnects the power company circuit when the Alternator is connected to your electrical load. When your normal power comes on, you can disconnect the Alternator from the load and connect the powerline to the load. These transfer switches are available from Forney Industries at a low cost and are good insurance against damaging the Alternator.

The power required to start any electric motor is considerably more than is required for keeping it running after it is once started. Some motors require much more current to start them than others. Split phase AC motors require more current to start under similar circumstances than other types. These are commonly used on easy starting loads such as on washing machines or where loads are applied after the motor is started, such as small power tools. Since they require five to seven times as much current to start as to run, their use should be avoided whenever possible, if the Alternator is already loaded near its maximum capacity. Capacitor motors and repulsion reduction motors require from two to four times as much current to start them as to run them. The current to start any motor varies with the load connected to it. An electric motor connected to an Air Compressor for example will require more amperage than a motor to which no load is connected.

## MAINTENANCE

**BRUSHES** -- Check the brushes for wear after about 1000 hours of operation and every few hundred hours of operation thereafter. They should be replaced when worn down to 1/2 inch. Whenever replacing brushes or removing them to do other service work, remove one brush at a time and put the screws back into the brush holder to hold the lead wire terminals in place so there will be no difficulty in connecting the wires to the correct positions.

**COMMUTATOR** -- A commutator in good condition has a glossy finish and is brownish in color. If it gets greasy, rough or dirty, it may be cleaned with very fine sandpaper. (Do not use emery cloth.)

**BEARINGS** -- All ball bearings used in these Alternators are packed with grease before assembly -- no further greasing is required. If they become rough or worn they should be replaced.

## LOCATING TROUBLE

If the Alternator does not work properly, first check the conditions under which it has been operating and then if necessary make the electrical tests as outlined below:

1. Is the speed correct? Check the speed with a tachometer or frequency meter and adjust the engine governor if necessary. If the Alternator cannot be kept to specified speed when it is loaded to its rated capacity the engine is too small, or is not working properly or the governor is not sensitive enough to hold the speed constant over a wide load range.
2. Is the Alternator overloaded? Check the nameplate for maximum safe load and if uncertain about the amount of load, check it with an ammeter and voltmeter.
3. Is the location satisfactory? See "Location" regarding sufficient ventilation if the Alternator is being operated in an enclosed area. If it is being operated under dusty or dirty conditions be sure all ventilation holes and slots are cleaned periodically.
4. Is the commutation satisfactory? With the Alternator in operation, notice whether there is any appreciable arcing or sparking at either the AC or DC brushes. See the article on brushes under "Maintenance".
5. The Alternator is equipped with a voltmeter to indicate that the unit is producing electricity. If the voltmeter does not register, check the output with a bulb or meter before deciding that the Alternator is not performing as it should.
6. If no output voltage is obtained at the outlet receptacles or output wires, disconnect all electrical leads and connect a voltmeter directly to the AC brushes. If no voltmeter is available, use any ordinary small 115 volt bulb (230 volt bulb on 230 volt Alternators). If normal voltage is obtained at the AC brushes but not at the output terminals, there must be an open circuit between these points. (CAUTION -- On 115/230 volt plants, the center brush is neutral and grounded. Check from this brush to each of the other two brushes.)



7. If no AC voltage is obtained at the brushes, check the excitor voltage by connecting to the DC brushes. The voltage should be at least 16 volts. This voltage will produce a dim light if a 115 volt bulb is used. If the DC voltage is satisfactory omit Step 8 and proceed with Step 9.
8. If no voltage is produced at the DC brushes, proceed as follows:
  - a. Remove each of the DC brushes to be sure they are clean and free in the holder. Examine the brush springs to make sure they have several ounces of tension. Replace all parts necessary.
  - b. One side of the DC circuit and one side of the AC circuit is connected or "grounded" to the alternator frame. The other side is said to be "live" or "hot". Any short circuit between the "hot" side or either circuit and any metal part of the alternator will result in a grounded condition which prevents the alternator from producing electricity. Carefully inspect all "hot" wires and terminals for evidence of a grounded condition.
  - c. Using an ohmmeter, check the field circuit for open circuits. To do this remove one of the field coil leads from the brush and check from this terminal to the other DC brush. If the circuit is open, check it for loose connections. If the alternator has a resistor in the field circuit, also check the resistance across it (or the part of it being used) to determine if it is "open". Replace all necessary parts.
  - d. If the trouble still is not located, disconnect all field leads and with an ohmmeter, check from either field coil terminal to the alternator frame to be sure the field coils are not grounded. If they are grounded, they should be replaced.
  - e. If the unit has not been operated for an extended period of time, the field poles may have lost "residual magnetism." To magnetize ("flash") the field poles use a 12 volt battery. Connect the negative terminal of the battery to the Negative (grounded) DC brush. Then connect the Positive battery terminal to the Positive DC brush for about one or two seconds. Do not connect for more than a few seconds or permanent damage to the field coils may result.
  - f. Remove all lead terminals from the AC brushes. If the alternator builds up voltage with these wires disconnected, there is a short circuit in the condensers or control box. Isolate and correct the short circuit.
  - g. If all the previous tests are of no avail, remove the armature and have it tested for opens, shorts and grounds on a growler. The same equipment and procedure as is used for testing DC generator armatures also applies to these armatures.
  - h. If the armature tests satisfactorily check the DC brush holders for grounds (this applies to metallic brush holders only).

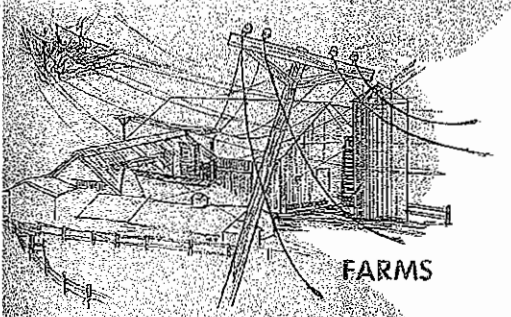

FARMS

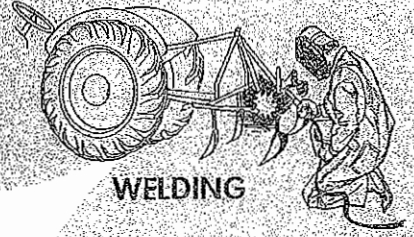

WELDING

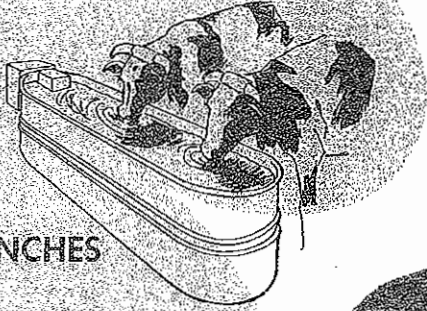

RANCHES

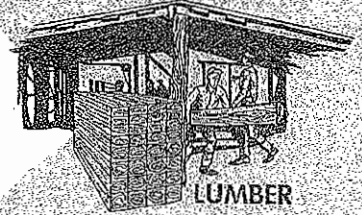
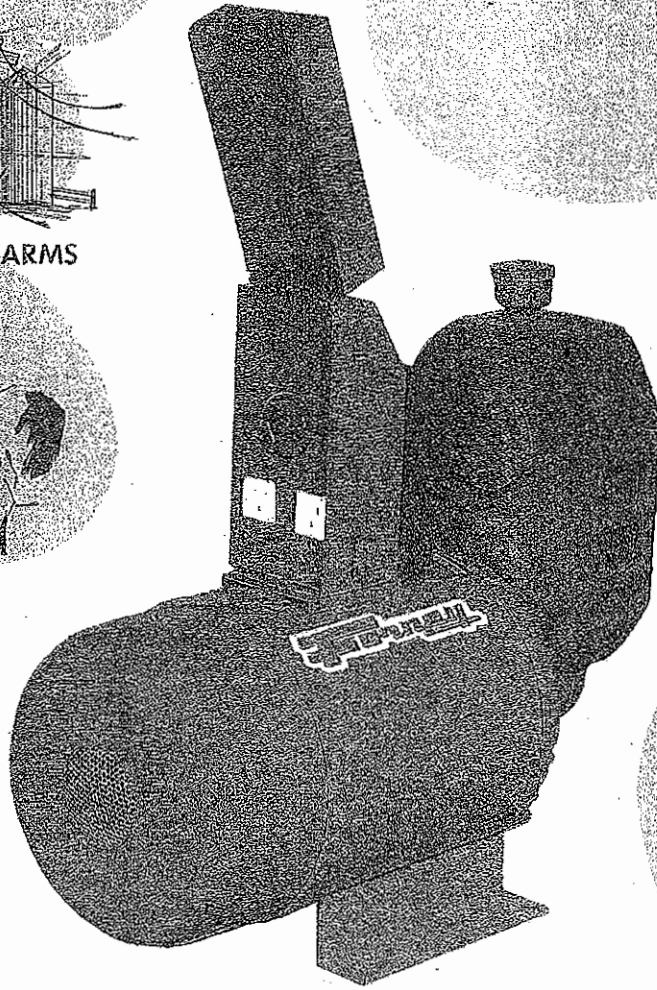

LUMBER

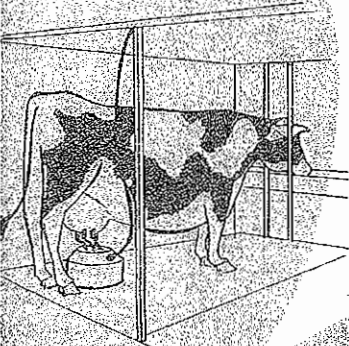

DAIRIES

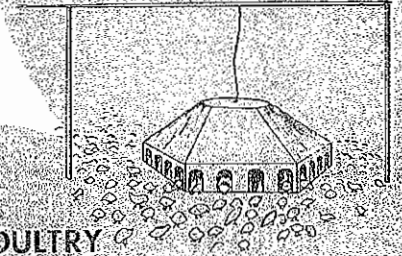

POULTRY

MODEL PTO

BE READY FOR ANY  
POWER FAILURE

*Forney*

POWER

TAKE-OFF

Generator

PORTABLE POWER —  
ANYWHERE - ANYTIME

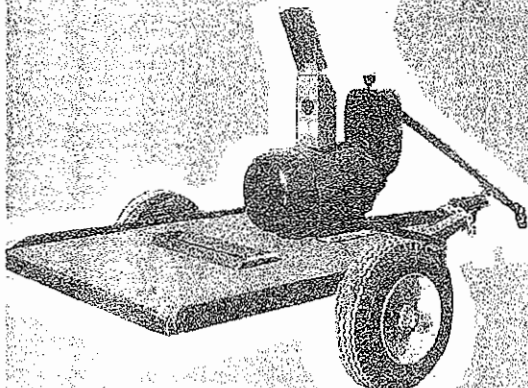

# THE FORNEY TRACTOR PTO POWER GENERATOR

A RUGGED HEAVY-DUTY ELECTRIC GENERATOR POWER PLANT THAT WILL PROVIDE AN ECONOMICAL AND DEPENDABLE SOURCE OF ELECTRICAL POWER EITHER AS A PORTABLE OR STANDBY UNIT.

## Have you counted the cost of POWER FAILURE?

Perhaps you have experienced power failure sometime. If so, we don't have to remind you that the losses can be heavy. Practically everything stops when power is cut off.

Just imagine — no lights, no water, no heat, no coolers, no freezer, no refrigerators, no power tools, no feeders, no milkers, no radio or TV, operative. In a moment's time, a tornado, hurricane, blizzard, flood or lightning, could plunge your whole operation into a tailspin — UNLESS you had AUXILIARY power.

However, not just any type power will do. The need is too crucial to take chances on your auxiliary power also failing. Never sacrifice quality for price when one failure could be disastrous.

## THE FORNEY TRACTOR PTO POWER GENERATOR —

is guaranteed to give satisfactory service. It is designed to be driven by a tractor power take off or other engine's source of power that will provide 520 RPM to the Generator gear box.

The gear train in the gear box has a step-up ratio of 6.92 to 1. A speed of 520 RPM is required to drive the Generator at 3600 RPM to deliver 60 cycle power. If the Generator is intended to be used for the 12,000 watt continuous duty level a horsepower of 26.4 will be required to operate the Generator. If the Generator will be used utilizing the full 15,000 watts of intermittent power, a tractor horsepower of 33 will be required.

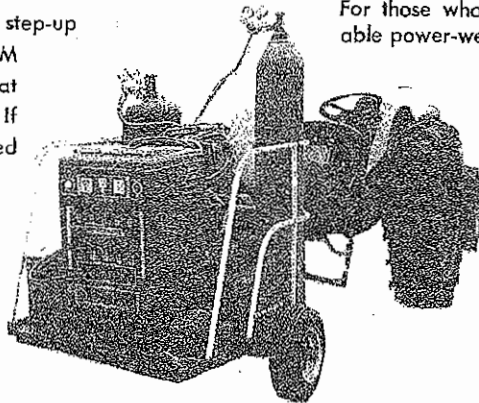

## OPTIONAL ACCESSORIES



### PTO DRIVE SHAFT

You'll need this PTO telescoping Drive Shaft to connect your Tractor to your PTO Generator. It is 4 ft. long and extends to 6 ft. Complete with splines to couple to the universal joints.

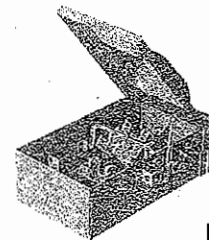

### LINE TRANSFER SWITCH

Required with any self-powered, non-automatic generator which is hooked into wiring system connected to hi-line. Change from hi-line to generator power, and back again, by throwing the lever.

## THE FORNEY TRACTOR PTO POWER GENERATOR

is equipped with a voltmeter for adjusting the speed and is also equipped in the same control box on the rear side, with the rain-type cover outlet connection for both 230 volt and 115 volt.

## AC ARC WELDER

The Forney 180 amp and 250 amp AC Arc Welders can both be used from the Power Generator by plugging them into the 230 volt outlet in the control box. The two 110-volt outlets are rated 15 amps each for lights, electric drills, etc.

## STANDBY POWER

For standby power on 230 volts, either the 230 volt plug-in can be used or, if the local codes require, direct connection can be made to the leads inside the control box.

## SERVICE WARRANTY

If within 1 year of your purchase date, your PTO unit fails to operate satisfactorily because of defects in workmanship or material, authorized repair will be made at our Fort Collins, Colorado factory, or by an authorized Factory Representative. For those who want the most complete and economical portable power-welder unit — begin with —

THE FORNEY PTO POWER GENERATOR; add a FORNEY CBBT REPAIR UNIT, plus a FORNEY ACETYLENE OUTFIT and FORNEY ACCESSORY KITS; place all upon a two-wheel trailer, attach power take-off to tractor.

NOW you are ready for any job, any place, whether there's power failure or not.

## FORNEY ARC WELDERS

Division of Forney Industries, Inc

Fort Collins, Colorado, U.S.A.

— Regina, Saskatchewan, Canada

# PTO SHAFT ADAPTERS

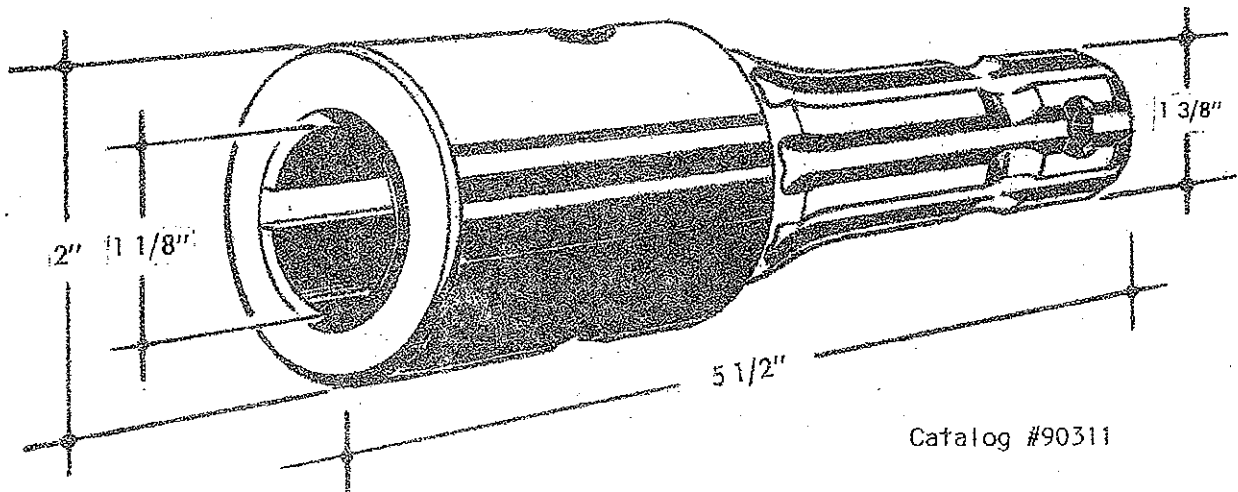

Catalog #90311

## PTO ALTERNATOR SHAFT ADAPTER

This PTO Alternator Adapter is an adapter with a fully splined male and a keyed female end to be used to attach to your PTO Alternator shaft and then to a PTO Shaft or tumbler. The size of the male spline and female end is as shown on the drawing above.

## PTO DRIVE SHAFT ADAPTER (REDUCER)

This PTO Drive Shaft Adapter or Reducer is available for the customer who desires an adapter or reducer which is fully splined to work with a tumbler bar he may already have. The size of the male and female spline ends are as shown below.

Catalog #90310

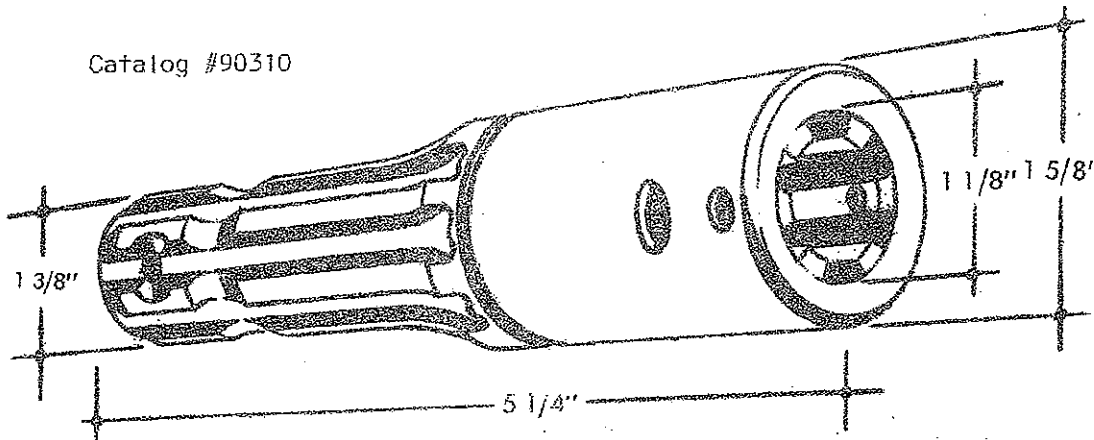

PRODUCT OF **FERROVIBRA INDUSTRIES, INC.**

BOX 563 FORT COLLINS, COLORADO 80521 PHONE (303) 482-7271 U.S.A.

REGINA, SASKATCHEWAN, CANADA

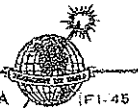

FI-45

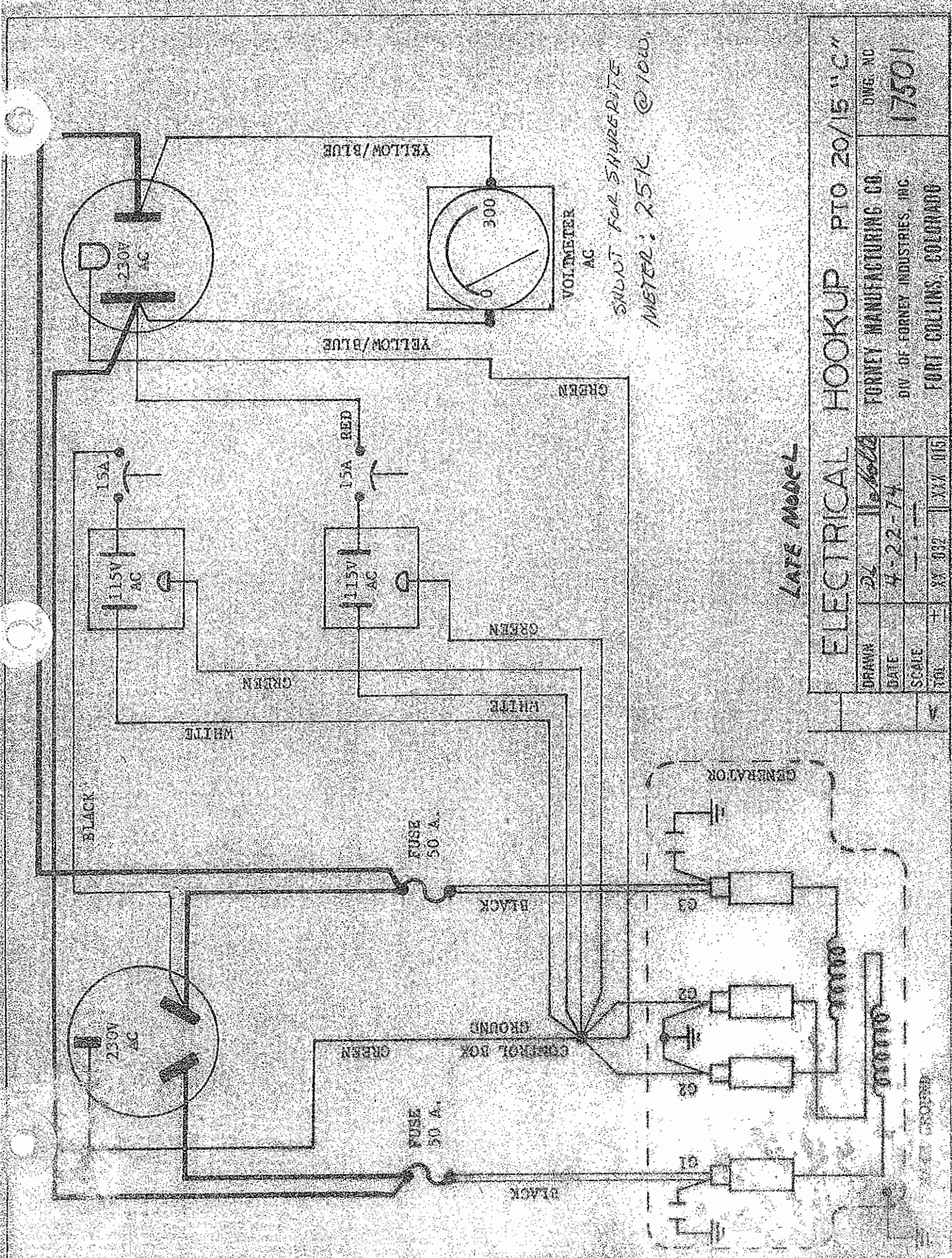

SKIDT FOR SHAPERITE  
METER: 251K @ 10W.

LATE MODEL

ELECTRICAL HOOKUP PTO 20/15 "C"		DRWG. NO.	17501
FORNEY MANUFACTURING CO.	DIV. OF FORNEY INDUSTRIES, INC.		
FORT COLLINS, COLORADO			
DRAWN	24	10/6/68	
DATE	4-22-74		
SCALE			
TITLE	XY 032	XY 015	

# WINCO GENERATOR PLANT MODEL P15PTOF-3/D

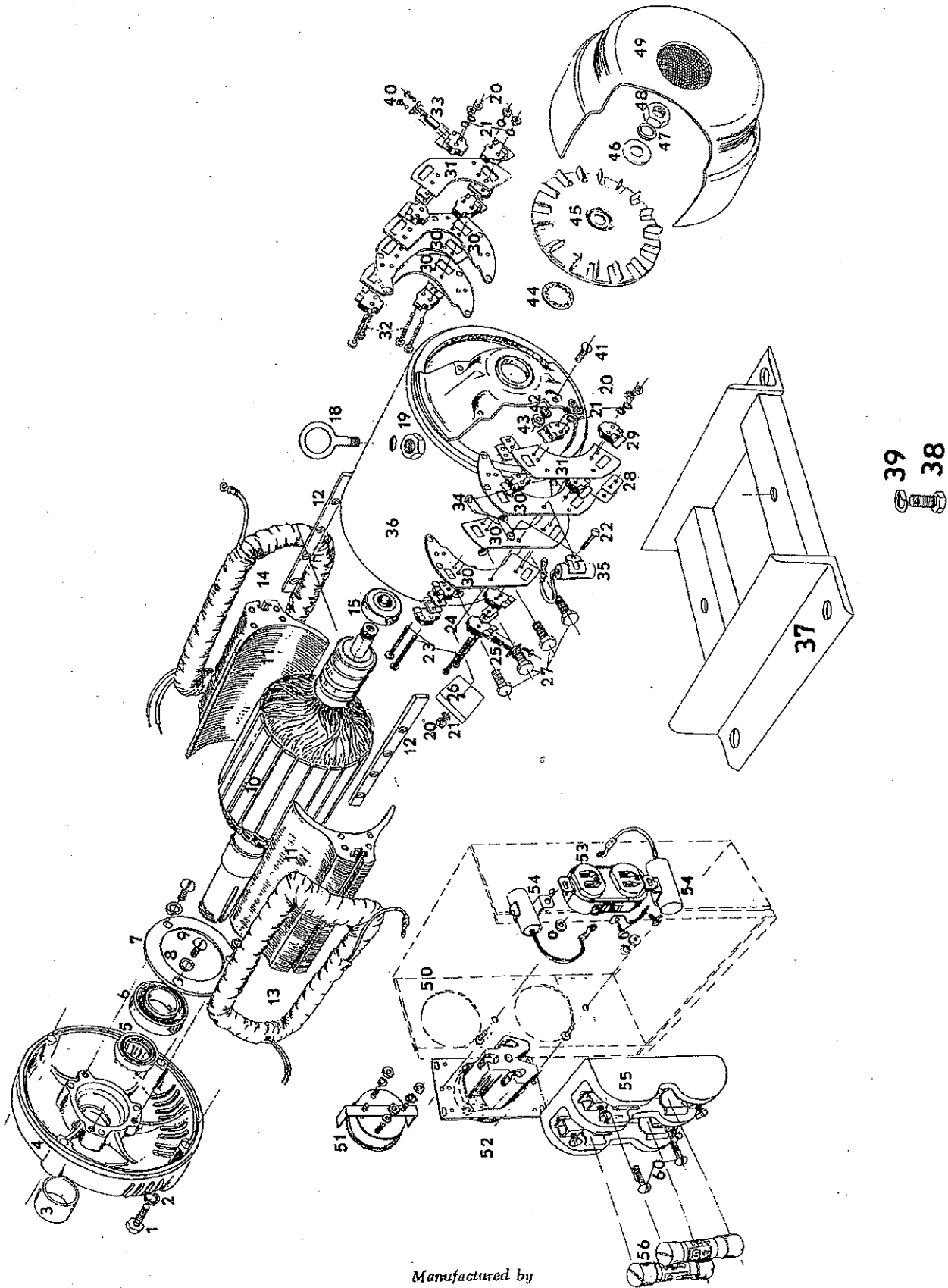

Manufactured by

## WINCO

Division of Dyna Technology, Inc.

East Seventh at Division / P. O. Box 3263 / Phone (712) 252-1821 / SIOUX CITY, IOWA 51102

# PTO (POWER TAKE OFF) ALTERNATOR

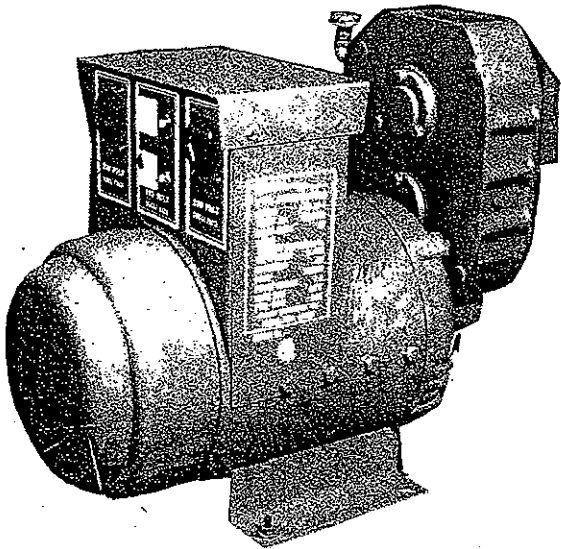

PERHAPS you have experienced power failure at some-time. If so, we don't have to remind you that the losses can be heavy. Practically everything stops when power is cut off - no lights, water, heat, coolers, freezers, refrigerators, power tools, feeders, milkers, radio and TV. In a moment's time a tornado, hurricane, blizzard, flood or lightning could plunge your whole operation into costly confusion - unless you have auxiliary power. Fasten this unit on a two-wheel trailer, attach the power take-off on your tractor and you are ready for any job any place, whether there is power or not.

## PORTABLE or STANDBY

### MOST COMMONLY USED MODELS

PTO-15-1	PTO-15-3	PTO-20-1	PTO-20-3
Cat.#600-0	Cat.#601-0	Cat.#605-0	Cat.#606-0

### FEATURES

- \* 3600 RPM Armature
- \* 540 RPM Tractor PTO Speed
- \* Precision Gear Drive
- \* Oil Bath Gear Case
- \* Pre-lubed Sealed Bearings
- \* Burn-out Proof
- \* Cool Running
- \* Minimum Frequency Variation
- \* No fuses or Breakers
- \* Calibrated Voltmeter
- \* Compact and Light Weight
- \* Long Brush Life
- \* Radio and TV Static Checked
- \* 230/115 Volt Outlets
- \* DC Windings
- \* No Drip Insulation
- \* Minimum Maintenance
- \* Full One-Year Warranty

ALL MODELS have the same precision gear drive and the alternators are all burn-out proof. 3600 RPM is a plus factor for easier motor starting due to the inertia factor. Quality design holds temperature rise to approximately 50% of what NEMA standards allow. It is an excellent unit for use as a standby power source because of the minimum frequency variation and radio and TV interference has been suppressed.

AUXILIARY POWER designed for both 115 volt and 230 volt, 60 cycle in both single phase and three phase. 520 RPM at the gear box PTO produces 3600 RPM on the armature. The control tower is equipped with a volt meter facing the shaft for easy reading and setting of the engine speed desired. The reverse side has a rain-type cover protecting the two 115 volt outlets and the one 230 volt outlet.

3600 RPM ARMATURE provides greater motor starting ability through the inertia factor. The rotating armature also provides portability by less weight (same watts - smaller package) compared to an 1800 RPM rotating fields type unit. The rotating armature type has proven to be a more rugged and durable unit.

540 RPM TRACTOR PTO SPEED - The gear reduction makes it possible for almost any tractor to drive this unit as the 540 RPM is a very low requirement. The engine powering the unit needs only the capability of producing 2 HP per 1000 watts to assure proper operation.

## GEAR DRIVE NOT CHAIN

The precision machined helical gears are incased in rugged line-bored cast iron and run in an oil bath requiring only regular automotive type gear oil. This means quieter operation, less breakage, no links to replace, etc.

## CONTROL PANEL

When the powering source maintains the proper RPM required, the unit will have little or no frequency variation (that is, using an engine equipped with a sensitive governor). The calibrated voltmeter is located facing forward so the operator can see the meter and adjust the powering engine properly. The same control panel is equipped with one 230 volt and two 115 volt outlets, sheltered with a covering door.

## ALTERNATOR

The case is aligned-grain, rolled, welded and honed. The armature rotates inside stationary fields on pre-lubricated sealed ball bearings. The insulation is drip-proof and is of a class rating allowing up to 130° C. temperature rise by NEMA standards. Designed to give protection lasting as long as the alternator lasts. The collapsible fields provide for positive overload protection (burn-out proof) and stops electrical output and is considered a "plus" over fuses and circuit breakers. Collapsible fields reduce continued overloading to a minimum creating longer life of the alternator. They have DC windings. Capacitors are included on both load circuits and exciter circuit to minimize interference on radio and TV. There are four commutator rings and four brushes per ring and held by a metallic brush holder. Tests have shown up to 5000 hours of brush life, so brush wear is at a minimum.

## STANDBY POWER

For standby power on 230 volts, either the 230 volt outlet can be used or, if the local codes require, direct connection can be made to leads inside the control box. To even increase its versatility, the alternators can be made portable by either skid or trailer mounting the unit thereby making it possible to move it to any place that you need electric power.

## GENERATOR WELDER POSSIBLE

We have good portable welders that can be used with the PTO Alternators as their source of power by plugging them into the 230 volt outlet. The 110 volt outlets are rated at 15 amps for lights, electric drills, etc.

For those who want the most complete and economical portable power-welder unit, begin with the Forney PTO Power Alternator, then add a Forney Model F Welder, plus a Forney Acetylene Outfit and Forney Accessory Kits; place all on a two-wheel trailer, attach the power take-off to your tractor and you are ready for any job any place, whether there is power or not.

## WARRANTY

Within one year of your purchase date, your PTO unit fails to operate satisfactorily because of defects in workmanship or material, authorized repair will be made at our Fort Collins, Colorado factory, or by an authorized Factory Representative.

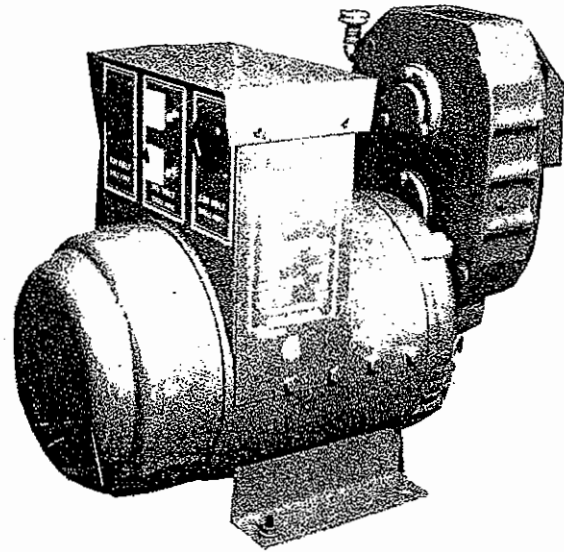

### SPECIFICATIONS of available PTO alternators

PTO-15 ALTERNATOR, single phase, 12,000 continuous, 15,000 intermittent, approx. 19,500 surge, starts 7.5 H.P. motor, runs 10-12 H.P. (25-35 H.P. tractor)

PTO-15 ALTERNATOR, three phase, 12,000 continuous, 15,000 intermittent, approx. 19,500 surge, starts 7.5 H.P. motor, runs 10-12 H.P. (25-35 H.P. tractor)

PTO-20 ALTERNATOR, single phase, 15,000 continuous, 20,000 intermittent, approx. 25,000 surge, starts 10 H.P. motor, runs 13-16 H.P. (30-40 H.P. tractor)

PTO-20 ALTERNATOR, three phase, 15,000 continuous, 20,000 intermittent, approx. 25,000 surge, starts 10 H.P. motor, runs 13-16 H.P. (30-40 H.P. tractor)

PTO-30 ALTERNATOR, single phase, 25,000 continuous, 30,000 intermittent, approx. 40,000 surge, starts 13 H.P. runs 20 H.P. 1800 R.P.M., 540 R.P.M. (50 H.P. tractor)

PTO-30 ALTERNATOR, three phase, 25,000 continuous, 30,000 watts intermittent, approx. 40,000 surge, starts 13 H.P. runs 20 H.P. 1800 R.P.M., 540 R.P.M. (50 H.P. tractor)

PTO-45 ALTERNATOR, single phase, 37,000 continuous, 45,000 intermittent, approx. 60,000 surge, starts 20 H.P. load, runs 30 H.P. 1800 R.P.M., 1000 R.P.M. on PTO, (tractor 75 H.P.)

PTO-45 ALTERNATOR, three phase, 37,000 continuous, 45,000 intermittent, approx. 60,000 surge, starts 20 H.P. load, runs 30 H.P. 1800 R.P.M., 1000 R.P.M. on PTO (tractor 75 H.P.)

PTO-60 ALTERNATOR, single phase, 50,000 continuous, 60,000 intermittent, approx. 80,000 surge, starts 26 H.P., runs 40 H.P. 1800 R.P.M., 1000 R.P.M. on PTO, (tractor 100 H.P.)

PTO-60 ALTERNATOR, three phase, 50,000 continuous, 60,000 intermittent, approx. 80,000 surge, starts 26 H.P., runs 40 H.P. 1800 R.P.M., 1000 R.P.M. on PTO, (tractor 100 H.P.)