

# INSTRUCTIONS # 55777

## FS-2C3 AUTO-DARKENING WELDING FILTER

Copyright © THREE NEW Machinery & Electron Co. Ltd.

Before use this auto-darkening welding filter, it is necessary to read these instructions. The performance of this product may not meet your requirement if it is not used or maintained properly by these instructions.

### 1. Introduction

Welcome to use the product of Auto-Darkening Filter (ADF) manufactured by THREE NEW Machinery & Electron Co. Ltd. ADF is a kind of novel labor protecting products in welding industry, which can provide sufficient eye's protection of welders against ultraviolet and infrared emissions. Our ADF product of FS-2C3, which is controlled by the electronic system, is a multifunctional, all-purpose and long-lived advanced welding appliance.

FS-2C3 is provided with solar battery, which can supply the inside electronic system with electric power while there is either sunlight or welding arc. There are redundancy lithium batteries inside the product which complement the power supply when the solar battery can not satisfy the energy requirement of the electronic system. Hence the product has long useful-life. FS-2C3 can distinguish the welding light from sunlight, accordingly switch to dark state from light state with fast speed in case that there is welding arc. As a result eye protection is obtained. Furthermore, special emission filtering glass made by our company is adopted, wherefore the transmission rate of ultraviolet or infrared is very small.

### 2. Technical Specification

The following table illustrates the main technical specification of FS-2C3.

| ITEM                     | DESCRIPTION   |
|--------------------------|---|
| Overall size             | 110×90×9 millimetre (4.33×3.54×0.35 inch)   |
| Size of vision field     | 96×41 millimetre (3.78×1.62 inch)   |
| Size of solar cell       | 95×16 millimetre (3.74×0.63 inch)   |
| Size of protecting plate | 101.5×46 millimetre (4.00×1.77 inch)  |
| Material of Crust        | High impact and fire-retardant ABS  |
| Gross weight             |   |
| Emission prevented       | Far Ultraviolet transmission rate: ≤ 0.001%<br>Infrared transmission rate(Average): Shade 9 ≤ 0.5%<br>Shade 13 ≤ 0.3% |
| On-off                   | Auto on, Auto off   |
| Shade No.                | Light State: DIN 4  |
|                          | Dark State: DIN 9-13, Adjustable continuously   |
| Switching speed          | ≤0.1 millisecond (From light state to dark state)   |
| Switching time delay     | 0.1~0.5 second (to light state)   |
| Operation temperature    | -5°C~55°C   |

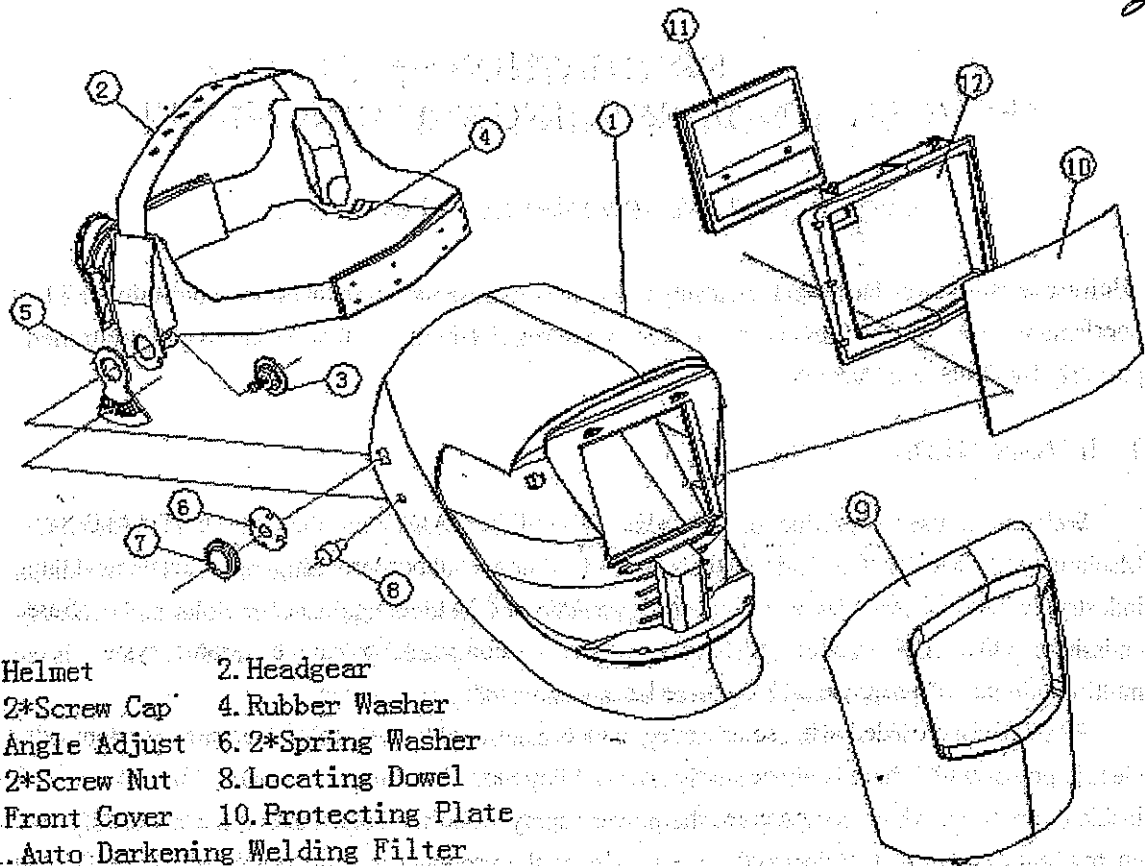

- 1. Helmet
- 2. Headgear
- 3. 2\*Screw Cap
- 4. Rubber Washer
- 5. Angle Adjust
- 6. 2\*Spring Washer
- 7. 2\*Screw Nut
- 8. Locating Dowel
- 9. Front Cover
- 10. Protecting Plate
- 11. Auto Darkening Welding Filter
- 12. Filter Retainer

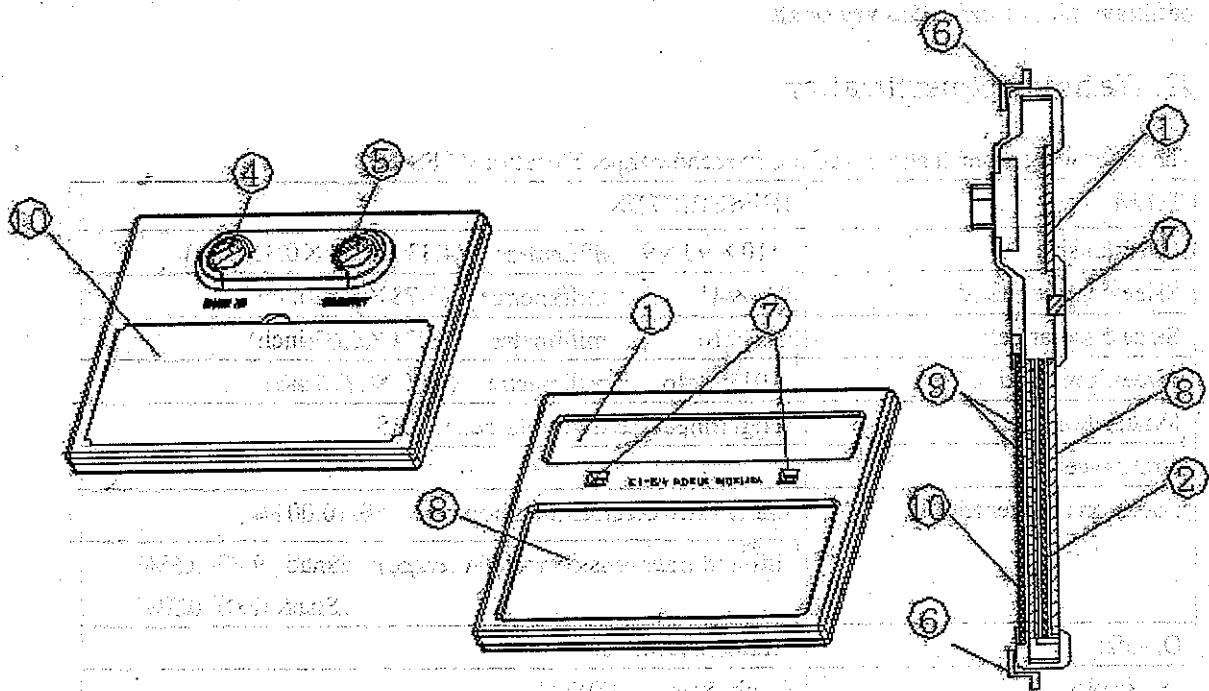

- 1. Solar Cell
- 2. Filtering Plate
- 4. Shade Adjust
- 5. Sensitivity Adjust
- 6. Filter Retainer
- 7. Sensor
- 8. Absorb Glass
- 9. LCD
- 10. Protecting Plate

The detailed structure of the product is shown in the figures attached.

#55777  
instructions

### 3. Applicable Sphere

FS-2C3 is applicable to all kinds of arc welding, but can NOT be used for protection against Oxyhydrogen cutting and laser welding.

### 4. Preparing to Use

It is important to read and comply with the following steps of using, and otherwise eye's injury may happen.

#### (1) Checking the Product

Before you use the ADF, it is helpful to do the following carefully.

- Observe the appearance of the product and check the brand name. Be sure that it is made by THREE NEW Co. Ltd and its type is FS-2C3.
- Examine the product carefully and confirm that there is no damage including the obverse and inverse side of the lens glass, the solar cell and the crust.
- Examine the operation of the product. Put the product near the incandescent arc lamp as closely as possible. It will switching to dark state from light state, or may be damaged.
- Remove the clear plastic of the protecting plate to begin to use.

If there is one of the above situations, please contact the agent or our company.

#### (2) Function Adjusting

There are two adjustable functions in FS-2C3 and it is important to set a proper operation mode of the product for good performance according to different welding conditions. They are **Shade No. (Dark State)** and **Sensitivity**. The following will provide details of using.

a) *Shade No.* Set a proper Shade No. for your welding conditions. Adjust the shade knob to a desired position to acquire the desired shade No. referring to the following table.

| Welding Process        | Welding Current (Ampere) |    |    |    |     |     |     |     |     |     |     |     |     |     |     |     |     |
|------------------------|--------------------------|----|----|----|-----|-----|-----|-----|-----|-----|-----|-----|-----|-----|-----|-----|-----|
|                        | 30                       | 40 | 60 | 80 | 100 | 125 | 150 | 175 | 200 | 225 | 250 | 275 | 300 | 350 | 400 | 450 | 500 |
| Covered Electrodes     |                          | 9  | 10 |    | 11  |     |     | 12  |     |     |     |     | 13  |     |     |     | 14  |
| MIG on Heavy Metals    |                          |    |    |    | 10  | 11  |     | 12  |     |     |     |     | 13  |     |     |     | 14  |
| MIG on Light Alloys    |                          |    |    |    | 10  | 11  |     | 12  |     |     | 13  |     |     | 14  |     |     | 15  |
| TIG on Metals & Alloys | 9                        | 10 | 11 | 12 |     |     |     | 13  |     |     |     | 14  |     |     |     |     | 15  |
| MAG                    |                          |    | 10 | 11 |     | 12  |     | 13  |     |     |     |     | 14  |     |     |     | 15  |
| Arc-Air Gouging        |                          |    |    |    |     | 10  |     | 11  | 12  |     | 13  |     | 14  |     |     |     | 15  |
| Plasma Jet Cutting     |                          |    |    | 11 |     |     |     | 12  |     |     |     | 13  |     |     |     |     |     |

**Note:**

- 1) The empty areas correspond to the ranges where the wilding operations are not usually used in the current practice of manual welding.
- 2) The term "heavy metals" applies to steels, alloy steels, copper and its alloy, etc.
- 3) According to the conditions of use, the next greater or the next smaller scale number can be used.

b) *Sensitivity.* Adjust proper sensitivity. If there is single welding machine, i.e. welding arc source, the high sensitivity is recommended to use which corresponds the "H" position near the sensitivity knob. However, there are always many welding machines in some industry fields. Thus proper sensitivity is important to ensure the product work well, or it will have effect on each other. Users can adjust the knob to acquire proper sensitivity. Note the "L" position means the lowest sensitivity that can be obtained.

(3) Installing

The ADF product must be used with the welding mask. It must be installed onto welding mask hard and reliable. Please note the following when you install FS-2C3 onto welding mask:

- The overall size of FS-2C3 is 110×90×9 millimetres (4.33×3.54×0.35 inches), accordingly the welding mask or the fittings must be allowable to install this size.
- There must be protecting plate on the welding mask in front of the ADF. The outside which has solar cell can not meet welding arc directly.
- The installing instructions in detail can refer to that of the welding mask.

5. After Using and Maintenance

- After welding you should check the cover lens. If it stained some dust, please wipe it off by soft cloth or wash by mild solution of soap. Do not use hard cloth or rough paper.
- Please store the product in a cool and dry location.
- In some situations the protecting plate may be scratched, pitted or cracked. In this way the protecting plate can be replaced to ensure the using of the product. Lift the new protecting plate and remove the clear plastic, replace the damaged one on the product.

6. Safety Warnings & Precautions

- Do no attempt to use the ADF which has been damaged anywhere.
- Keep work area clean. Cluttered areas invite injuries.
- Keep children away.
- Store idle equipment. When not in use, tool must be stored in a dry location.
- Do not use the machines or power tools in damp or wet condition and Keep work area well lighted. Do not use the product in the presence of flammable gases or liquids.
- Maintenance. Service and maintenance should be performed regularly by a qualified technician for your safety.

**Warning:** the warning, cautions, and instructions discussed above can't cover all the conditions and situations that may occur. It must be understood by the operator that common sense and caution are factors, which cannot be built in to this product, but must be supplied by the operator.